

FIELD MANUAL

LARGER UNIT OPERATIONS

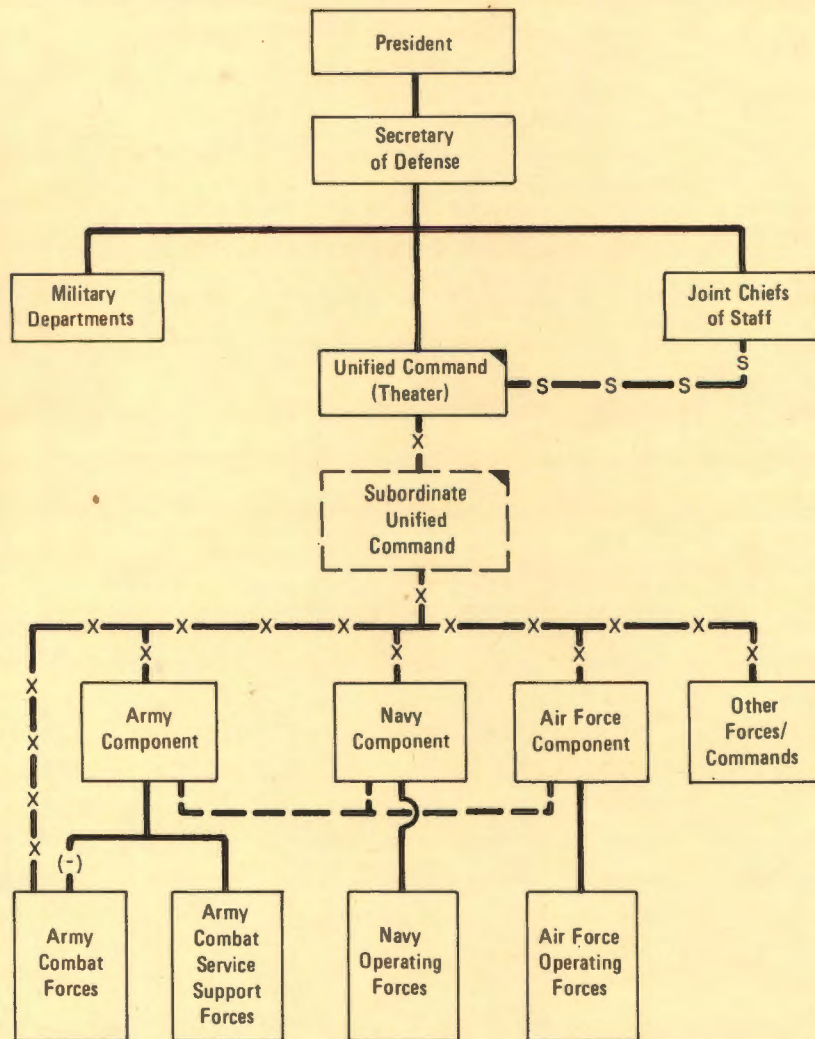

PREFACE

This manual prescribes Army level doctrine and guides members and staffs for the establishment, organization, mission, and employment of Army corps, the numbered army when employed, and the theater army. The manual defines interrelationships and functions of the various levels and includes their combat, combat support, and combat service requirements to conduct operations in all terrain and weather. The manual also discusses operations of Army divisions and the Army with strategic mobility and support ground units. Army doctrine is presented herein, however, some items regarding policies, procedures, or techniques have been extracted

This test publication is provided to disseminate the latest thought on larger unit operations. Users are requested to use this publication as the coordination manuscript and submit recommended changes or comments to Commander, US Army Command and General Staff College, Fort Leavenworth, Kansas 66027. Comments should be prepared using DA Form 2028 and should be submitted not later than 1 August 1974. US Army schools are further requested to indicate their initial distribution requirements during the first year of publication, if different from the schools' current DA Form 12-series accounts.

STRUCTURING PRINCIPLES	██████████
ARMY ROLE	██████████
THEATER OF OPERATIONS	██████████
THEATER PLANNING	██████████
THEATER ARMY	██████████
NUMBERED ARMY	██████████
THE CORPS	██████████
CORPS OPERATIONAL PLANNING	██████████
FORWARD DEPLOYED CORPS	██████████
CORPS CONTINGENCY FORCE	██████████
OFFENSIVE OPERATIONS	██████████
DEFENSIVE OPERATIONS	██████████
RETROGRADE OPERATIONS	██████████
TACTICAL NUCLEAR OPERATIONS	██████████
COMBAT SUPPORT	██████████
COMBAT SERVICE SUPPORT	██████████
INDEX	██████████

PREFACE

This manual prescribes Army test doctrine and guidance to commanders and staffs for the establishment, organization, administration, and employment of Army corps, the numbered army headquarters when employed, and the theater army. The manual defines the roles, interrelationships, and functions of the various levels of command to include their combat, combat support, and combat service support requirements to conduct operations in all forms and levels of conflict. The manual also discusses operations of other Services that provide the Army with strategic mobility and support ground tactical operations. Army doctrine is presented herein; however, some interpretations regarding policies, procedures, or techniques have been extracted from non-Army publications; e.g., international standardization agreements (STANAG's) and Joint Chiefs of Staff (JCS) publications.

Most chapters include a doctrinal recapitulation that summarizes the more significant doctrine contained within the chapter. These summaries are not necessarily all-inclusive; however, they do provide the highlights of the chapter and facilitate a rapid review for the reader.

Chapter 1 outlines the scope and purpose of the manual and defines the basic role of the US Army in defense of the United States.

Chapter 2 presents a limited discussion of joint, unified, and combined organizations to provide a basic understanding of the functions and responsibilities of commanders and staffs of these larger units. Particular emphasis is given to the role these higher echelons play in the provision of operational direction to combat forces, normally corps, under their operational command.

Chapter 3 outlines the organization, mission, and functions of the theater army; its major subordinate elements; and the numbered army headquarters when exceptionally employed as the next tactical echelon above the corps.

Chapter 4 is devoted to discussion of the organization and functions of the corps. A clear distinction is made between a forward deployed corps and a corps contingency force. The conduct of combat, combat support, and combat service support operations by each type of corps is addressed, as well as those operational considerations applicable to the employment of both types of corps. A section concerning the conduct of tactical nuclear operations at the corps level is also included.

LARGER UNIT OPERATIONS

INTRODUCTION

	Paragraph	Page
CHAPTER 1. INTRODUCTION	1-1-1-4	1-1
2. THEATER ORGANIZATION AND OPERATIONS		
Section I. Theater of operations	2-1-2-4	2-1
II. Organization of a US theater of operations	2-5-2-6	2-4
III. Theater planning	2-7-2-11	2-6
IV. Operational considerations	2-12-2-17	2-8
CHAPTER 3. MISSION, ORGANIZATION, AND FUNCTIONS OF ARMY ECHELONS ABOVE CORPS		
Section I. Theater army mission and organization	3-1-3-5	3-1
II. Theater army functions	3-6-3-9	3-3
III. The numbered army headquarters	3-10-3-13	3-9
CHAPTER 4. THE CORPS		
Section I. General	4-1-4-4	4-1
II. Operational planning	4-5-4-8	4-3
III. Corps operations in an established theater	4-9-4-13	4-5
IV. Corps contingency force operations	4-14-4-18	4-6
V. Corps offensive operations	4-19-4-28	4-9
VI. Defensive operations	4-29-4-36	4-17
VII. Retrograde operations	4-37-4-42	4-22
VIII. Tactical nuclear operations	4-43-4-46	4-23
IX. Combat support of the corps	4-47-51	4-25
X. Combat service support	4-52-4-54	4-31
APPENDIX A. REFERENCES		A-1
INDEX		Index-1

CHAPTER 1

INTRODUCTION

1-1. Purpose and Scope

a. This manual outlines doctrine for the organization, deployment, and employment of corps and higher Army echelons and provides the principles upon which to make judgments as local circumstances influence the application of doctrine. It provides the doctrinal basis for establishing the scope and nature of operational and administrative tasks and functions of the corps and higher Army echelons and provides a framework for developing Army organizations.

b. The doctrine in this test manual is defined as enlightened, tentative statements of what will usually work best. It encompasses those principles and policies that have been derived from the study of experience and realistic simulations. Doctrine should indicate and guide, but not bind in practice. Its application requires judgment in adapting to the peculiarities of the situation, since textbook conditions will rarely ever exist. Recommendations and supporting rationale for changes to this doctrine should be sent to the Commandant, US Army Command and General Staff College, Fort Leavenworth, Kansas 66027.

c. Other Service components and echelons higher than theater army, to include US unified commands and combined commands, are treated only as necessary to insure understanding of the functions, responsibilities, and relationships of those echelons as they apply to theater army and the corps.

1-2. Basic Principles and Considerations

a. Civilian Control.

(1) The military forces of the United States are subject to civilian control. The Constitution and statutes of the United States and Departmental regulations establish the commanders' responsibility to the President, as Commander in Chief, through a chain of command.

(2) It is imperative that this chain of command be used to give assessments and timely advice on the organization, deployment, and

employment of forces so that the responsible civilian authorities clearly understand the judgments of the military commanders. When the civilian authority has reached a decision, it is carried out by the Armed Forces with full respect for international and United States laws.

b. Realistic Force Structuring.

(1) This field manual considers the realities of in-being Army forces and their capabilities and limitations. Thus great emphasis must be placed on the art of organizing and structuring flexible, realistic, austere forces that achieve optimum combat capability through improved mobility and communications; skilled and disciplined planning and execution; employment of innovative advanced concepts that are within the state of the art; and heavy reliance on the Air Force for airlift, air defense, reconnaissance, and close air support.

(2) Army forces and leaders must be imbued with a sense of discipline, dedication, and purpose that will complement austere forces and guard against proliferation of nonessential units, materiel, systems, and services.

(3) Reliance on support of the other Services and the need for mutual confidence is recognized as an important aspect of land warfare. The employment of joint Army and Air Force forces is certain to be the norm regardless of the nature of the conflict.

c. Operational Environments.

(1) In some theaters forward deployed Army forces may require reinforcement and buildup in time of hostilities; conversely, Army forces may be deployed into areas where no US infrastructure exists. Each of these situations is addressed in chapter 4.

(2) US forces may or may not employ nuclear or chemical weapons. Formal treaties or agreements may inhibit the freedom of military action. Similar inhibitions may arise from foreign policy considerations and international law. Operational planning must always consider these factors.

(3) The initiation of nuclear warfare on any

scale is of grave concern to both the United States and other countries that may be affected. The use of tactical nuclear weapons in defense of friendly foreign countries raises moral and political questions that must properly be decided by civilian authorities. The possibility of their use by either combatant requires great vision in planning.

(4) Once initiated, combat operations in an active nuclear environment will require major adjustments. Of primary importance to the theater commander, is the intensity of nuclear warfare. Restraints on the types of targets, size and number of weapons, as well as types of bursts, may be imposed by agreement or unilateral US policy. The resulting intensity of nuclear warfare will dictate, in large measure, the effectiveness of maneuver by ground combat forces. Restrictions on the use of nuclear weapons will be based on international agreements and national policy, as well as operational considerations.

d. Impact of Nuclear and Chemical Weapons and Defensive Biological Operations. US Policy—

(1) Renounces first use of lethal and incapacitating chemicals.

(2) Confines military programs for toxins to research for defensive purposes only.

(3) Renounces the use of biological agents and weapons and all other methods of biological warfare.

(4) Confines military biological research to defensive measures.

The possible employment of nuclear weapons or the initiation of enemy chemical or biological operations requires emphasis on flexibility and mobility of maneuver forces and combat service support systems to minimize vulnerability to attack. Simplicity of plans, dispersion, and skillful execution may reduce the likelihood and effects of such attacks. During peacetime, all commanders must evaluate the monetary and personnel savings gained by consolidation of these facilities against their possible destruction in case of nuclear war.

1-3. The Army Role

a. General.

(1) The primary function of the Army is to organize, equip, and train Army forces for the conduct of prompt and sustained combat operations on land—specifically, forces to defeat enemy land forces and to secure, occupy, and defend land areas. Defeat of the enemy is accomplished by generating a relative superiority of combat power at the decisive time and place. This is not to infer that a relatively inferior

force cannot be decisive. To the contrary, an inferior force, highly disciplined and skillfully led, that capitalizes on its strengths and the enemy's weaknesses, can indeed be successful. Land combat is accomplished through the functions of intelligence; mobility; firepower; command, control, and communications; and combat service support.

(2) The prescribed functions of the Military Departments and Services are contained in JCS Pub 2 and AR 10-1. The Army functions are summarized in succeeding paragraphs.

b. Functions of the Department of the Army. The Department of the Army is responsible for the preparation of land forces necessary for the effective prosecution of war except as otherwise assigned and, in accordance with integrated mobilization plans, for the wartime expansion of peacetime components as authorized by the Congress. The US Army, within the Department of the Army, includes combat, combat support, combat service support, and other forces as may be authorized by Congress. A summary of these functions is listed below.

(1) Organize, equip, train, and provide Army forces for—

(a) Sustained combat operations on land.

(b) Defense of the United States against air attack.

(c) Joint amphibious and airborne operations.

(d) Assignment to a unified or specified command.

(2) Prepare forces, establish reserves of equipment and supplies, and plan for the expansion of peacetime components to meet the needs of war.

(3) Formulate doctrine and procedures for organizing, equipping, training, and employing Army forces.

(4) Provide an organization capable of furnishing adequate, timely, and reliable intelligence for the Army.

(5) Develop, garrison, supply, equip, and maintain bases and other installations.

(6) Provide, as directed, such forces, military missions, and detachments for service in foreign countries.

(7) Conduct the following activities:

(a) The administration and operation of the Panama Canal.

(b) The authorized civil works program, including projects for improvement of navigation: flood control, beach erosion control, and other water resource developments in the United States, its territories, and its possessions.

(c) Certain other civil activities prescribed by law.

c. Secretary of the Army.

(1) The Secretary of the Army, appointed by the President with the advice and consent of the Senate, is the head of the Department of the Army. Subject to direction, authority, and control of the President, as Commander in Chief, and of the Secretary of Defense, the Secretary of the Army is responsible for and has the authority to conduct all affairs of the Army.

(2) These affairs include, but are not limited to, those necessary or appropriate for the training, operation, administration, logistic support and maintenance, welfare, preparedness, and effectiveness of the Army, including research and development. The Secretary of the Army does not exercise operational command over Army forces assigned to a unified or specified command, but is responsible for their administration and support.

d. Chief of Staff, US Army. The Chief of Staff, US Army, as the principal military adviser to the Secretary of the Army, plans, develops, and executes the Army program. He is directly responsible to the Secretary of the Army for the efficiency and discipline of the Army, its state of readiness for military operations, and the plans therefor. As a member of the Joint Chiefs of Staff he serves with that corporate

body as a military adviser to the President, the National Security Council, and the Secretary of Defense.

1-4. References

a. Users should employ this manual in conjunction with FM 100-5, FM 100-10, FM 101-5, the FM 101-10-series, and other appropriate field manuals listed in the appendix. When applying doctrine contained in this manual to joint operations, users should also consult joint doctrine promulgated in appropriate JCS publications, which are also listed in the appendix.

b. This manual is in consonance with the following international standardization agreements, except for modifications required by changes in the Army organizational structure.

TITLE	NATO STANAG	CENTO STANAG	SEATO SEASTAG	ABCA SOLOG
Rear Area Security and Area Damage Control	2079	2079	2079	48R
Relief of Combat Troops	2082	2082	2082	--
Fire Coordination in Support of Land Forces	2099	2099	2099	--
Friendly Nuclear Strike Warning to Armed Forces Operating on Land	2104	2104	--	130
Recognition and Identifica- tion of Forces on the Bat- tlefield	2129	2129	2129	--
Offensive Air Support Opera- tions	2134	2134	--	--

CHAPTER 2

THEATER ORGANIZATION AND OPERATIONS

Section I. THEATER OF OPERATIONS

2-1. Theater of Operations

a. A theater of war is the total land, sea, and air area that is, or may become, involved directly in the operations of war. A theater of war has no definable limits and may consist of one or more theaters of operations. The term "area of war" is prescribed for joint and combined usage, and is synonymous with the term "theater of war." (JCS Pub 1.)

b. A theater of operations is that portion of a theater of war necessary for military operations, pursuant to an assigned mission, and for the administration and support incident to such operations. The theater of operations must be sufficient to allow for the allocated forces and their support. Where geographical limitations dictate, offshore land and sea areas may be required in the area of operations. The term "area of operations" is prescribed for use in joint or combined operations, and is synonymous with the term "theater of operations." (JCS Pub 1.)

2-2. Commander of the Unified Command (Theater)

a. The President, through the Secretary of Defense and with the advice and assistance of the Joint Chiefs of Staff, establishes unified commands on an area or functional basis for the performance of a broad continuing mission, or for the conduct of specific military operations.

b. A unified command consists of significant assigned components of two or more Services, each Service with its own component commander. When the President establishes a unified command that includes a large US Army contingent, Department of the Army, in coordination with the unified command commander, will normally establish a theater army. US Army forces in a theater of operations are usually assigned to a theater army (chap 3).

c. The commanders of unified commands are

responsible to the President, through the Secretary of Defense, for the accomplishment of assigned missions.

d. Commanders of unified commands are authorized to exercise operational command over the forces assigned. Operational command comprises those functions of command involving the composition of subordinate forces, the assignment of tasks, the designation of objectives, and the direction necessary to accomplish the mission. Operational command is exercised through Service component commanders or through the commanders of subordinate forces established by the commander exercising operational command. Operational command does not include matters of administration, discipline, internal organization, and unit training, except when a subordinate commander requests assistance (JCS Pub 1 and 2). However, operational command includes directive authority necessary to coordinate logistic and administrative policies and procedures. The terms "operational command" and "operational control" are synonymous; however, the term "operational command" is uniquely applied to indicate the operational control (authority) exercised by the commanders of unified commands over assigned forces (JCS Pub 2). The term "operational control" is used in all other cases.

2-3. Chain of Command (US Theater)

a. The chain of command extends from the President, through the Secretary of Defense, to the commander of the unified command. Strategic and operational direction of US forces runs from the President, to the Secretary of Defense, and through the Joint Chiefs of Staff, to the commander of the unified command (fig 2-1). The President, the Secretary of Defense, or the Joint Chiefs of Staff, by the authority and direction of the Secretary of Defense, issue orders to such commanders.

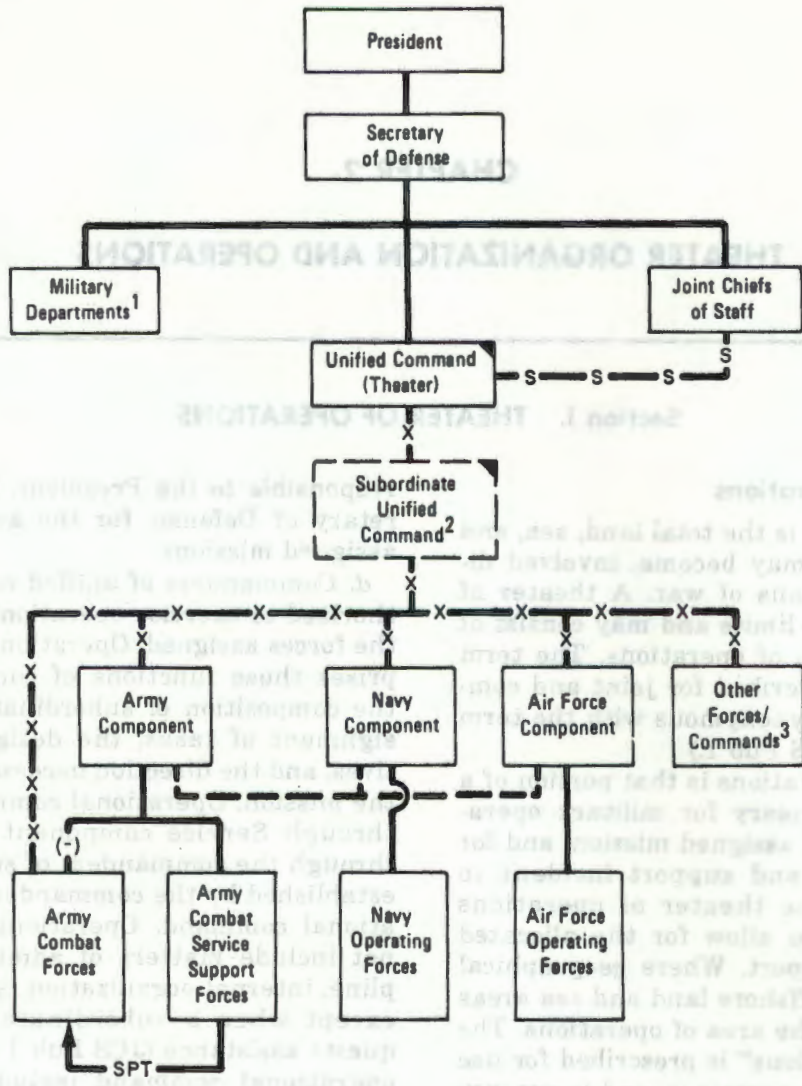

LEGEND

- Joint.
- Command.
- Direct coordination and common, joint, or cross-Service support.
- SPT — Combat service support.
- X—X— Operational command/control.
- S—S— Strategic and operational direction.
- (-)— Command less operational control.

¹ Responsible for the preparation of military forces, their administration, and support for component commands.

² May be formed as required and as authorized.

³ May include uni-Service force or joint task force.

Figure 2-1. Chain of command for an illustrative theater of operations.

b. The chain of command, for purposes other than the operational direction of unified commands, runs from the President to the Secretary of Defense, to the Secretaries of the Military Departments, and then to the Service component commanders.

2-4. Combined Operations (Theater)

a. Combined operations involve the military forces of two or more allied nations acting

together for the accomplishment of a single mission. To insure the required coordination and unity of effort, a combined command may be established. The organization of a combined theater and the command relationships within it will be determined by international agreements.

b. International standardization agreements set forth the procedures for establishing unity of effort of combined forces.

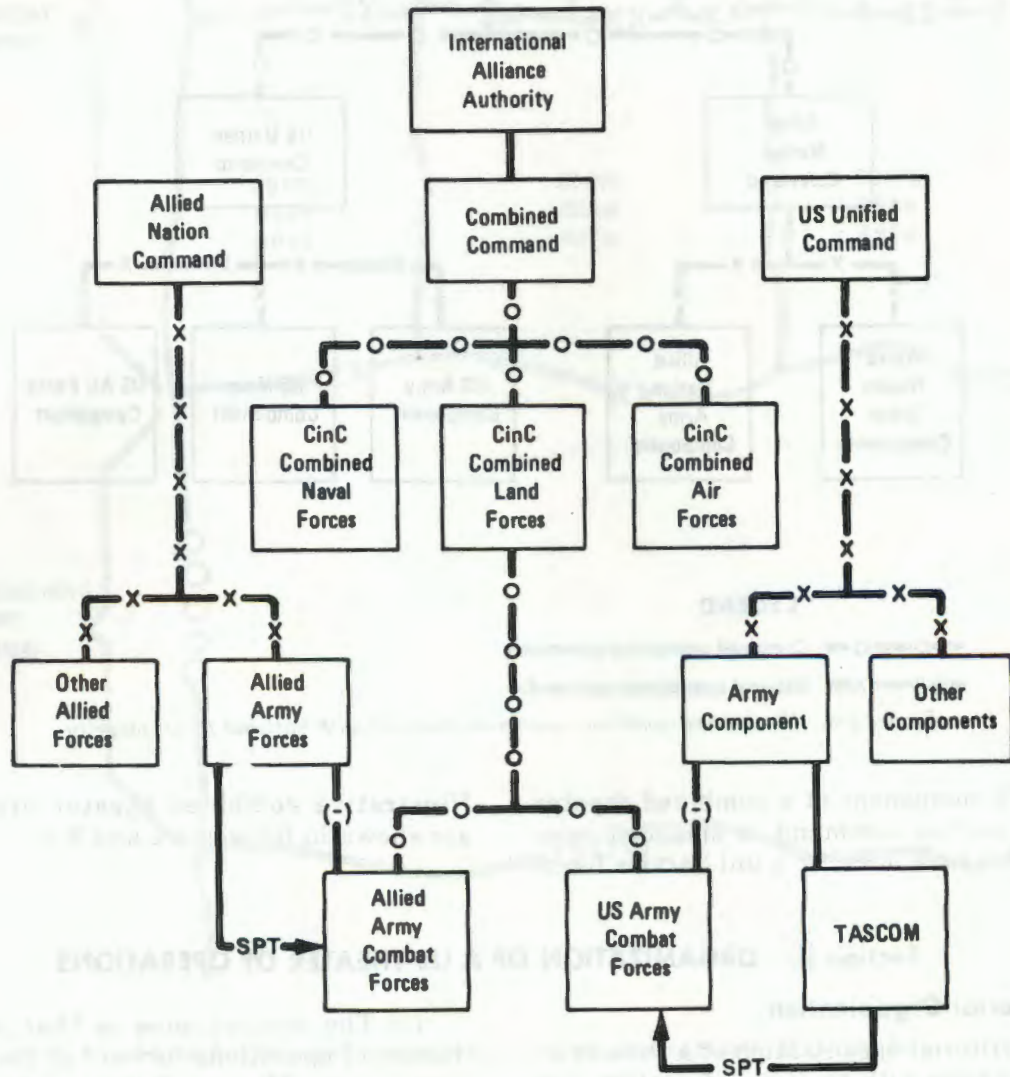

LEGEND

- Combined operation command/control.
- X— Operational command less that operational control relinquished to the combined command by international agreement.
- SPT— Combat service support.
- Command.
- (-)— Command less operational control.

Figure 2-2. Illustrative combined command structure by functional components.

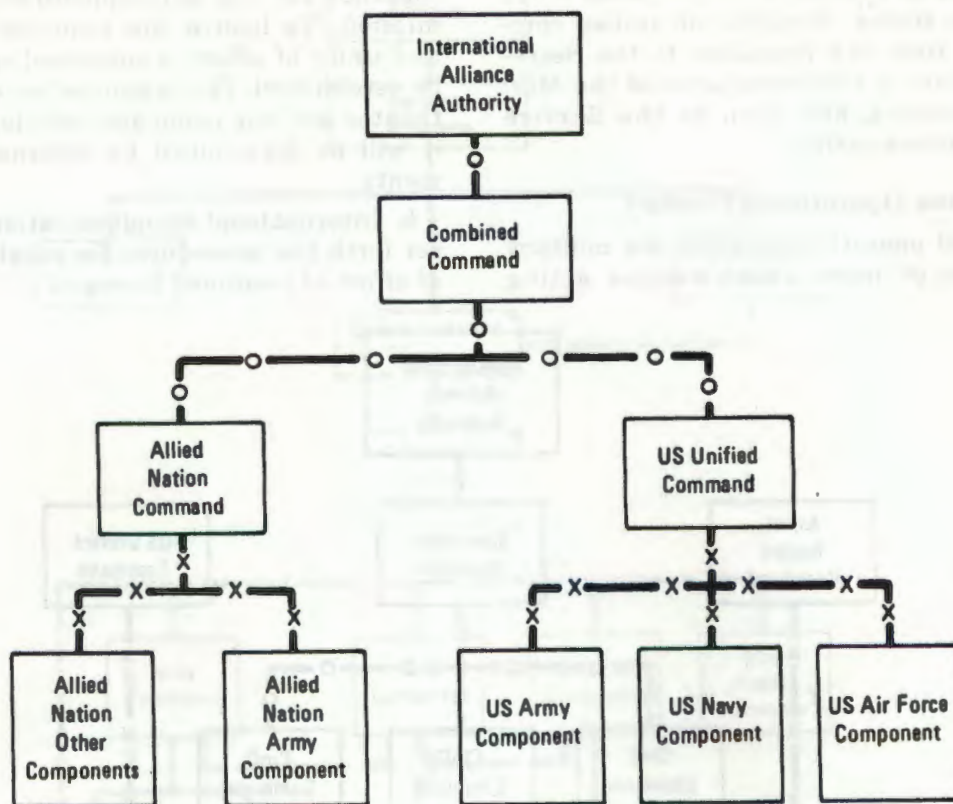

LEGEND

- Combined operational command.
- X—X— National operational command.

Figure 2-3. Illustrative combined command structure with national force integrity.

c. The US component of a combined theater may be a unified command, a specified command, a joint task force, or a uni-Service force.

Illustrative combined theater organizations are shown in figures 2-2 and 2-3.

Section II. ORGANIZATION OF A US THEATER OF OPERATIONS

2-5. Territorial Organization

a. The territorial organization of a theater of operations varies with the type of conflict and operational environment, the stage of theater development, and the nature of the planned operations. An established theater of operations in a mature state of development will normally be divided by the theater commander into a combat zone and a communications zone (COMMZ). Within a theater, the theater commander normally will assign territorial responsibility for the combat zone to the corps by designating lateral and rear boundaries. The corps rear boundaries would delineate the combat zone from the COMMZ.

(1) The combat zone is that part of the theater of operations forward of the corps rear boundaries. The combat zone includes the ground, air, and sea areas within which the commander can directly influence the progress or outcome of operations by maneuvering his forces and by delivering fires with fire support systems under his control or command. It may also include any areas necessary for the operation or support of other Service elements based in the combat zone. Its size depends on the mission, organization, and equipment of the force involved; whether the operational environment is nuclear or nonnuclear; enemy capabilities; the physical environment; and interna-

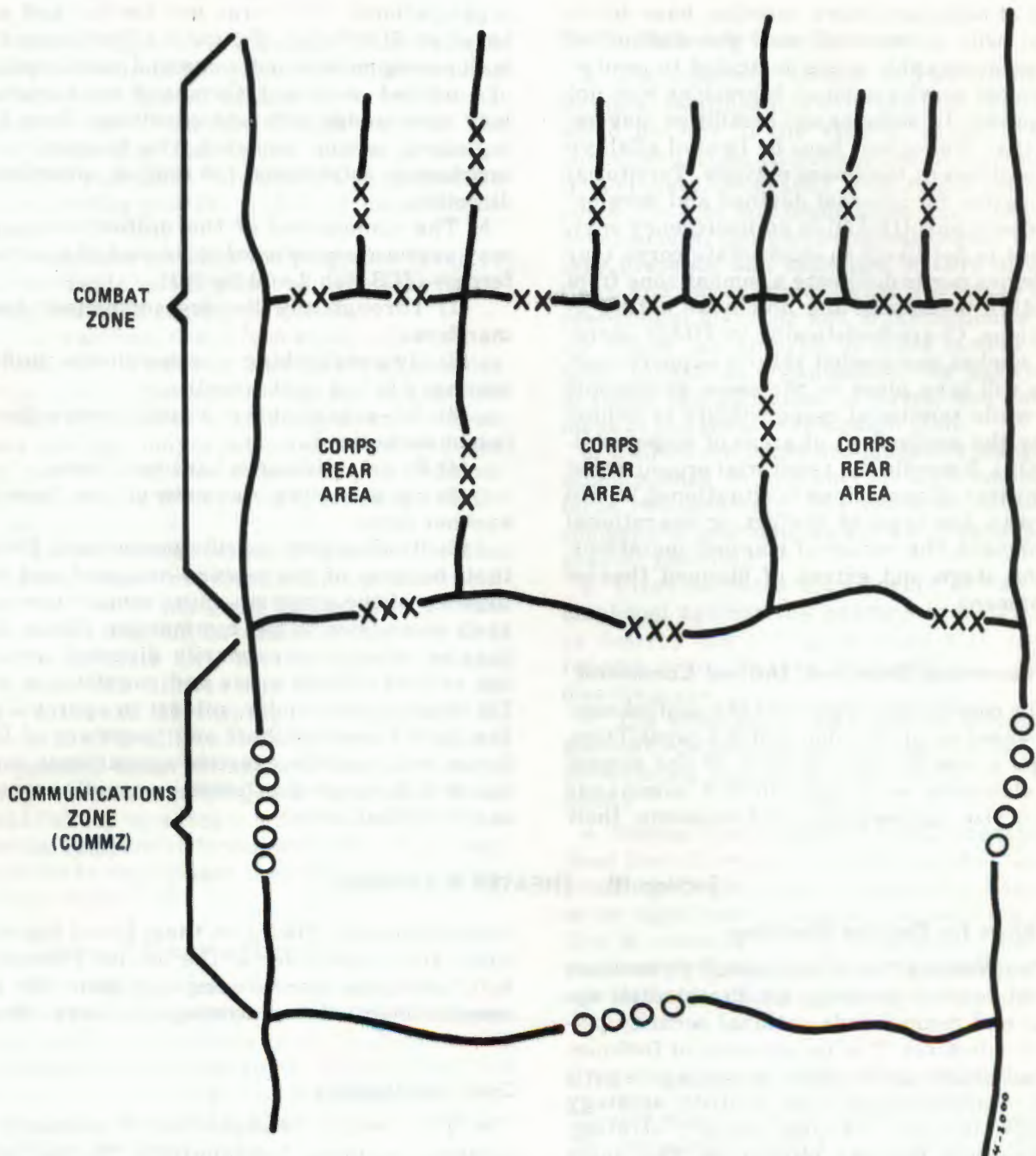

Figure 2-4. Territorial organization of an illustrative theater of operations.

tional agreements or other political considerations (fig 2-4).

(2) In a fully developed theater, the communications zone is that part of a theater of operations behind the combat zone. It contains the lines of communication, combat service support complexes, and other facilities and agencies required for support of theater forces. The communications zone includes sufficient area for defense of installations and dispersion and any area necessary for the operation or sup-

port of Sister Service elements based outside the combat zone. The rear boundary of the communications zone may coincide with the rear boundary of the theater of operations. FM 100-10, *Combat Service Support*, provides a detailed discussion of the development of the communications zone

b. In contingency operations the development of a theater without established facilities may result in a different form of territorial organization. Since this type of operation will gener-

ally be of relatively short duration, base development will be minimal, and the distinction between geographic areas dedicated to combat and combat service support operations may not be required. In some cases, hostilities may require that the logistic base be located offshore or on a different landmass entirely. Territorial organization for internal defense and development operations (IDAD) in an insurgency environment is not likely to incorporate corps rear boundaries nor to delineate a combat zone from a COMMZ because of the nonlinear nature of operations. Characteristically, in IDAD operations, combat and combat service support operations will take place in the same geographic area, while territorial responsibility is delineated by the assignment of areas of responsibility (AOR). Accordingly, territorial organization of a theater of operations is situational; it will vary with the type of conflict or operational environment, the nature of planned operations, and the stage and extent of planned theater development.

2-6. Command Structure, Unified Command

a. The commander organizes the unified command based on his mission and the capabilities, strengths, and Service identity of the component elements. Although unified commands vary in size, composition, and missions, their

organizational structures are similar and are based on JCS Pub 2. Figure 2-1 illustrates the major components and command relationships of a unified command. Command relationships may vary under different conditions from the unilateral scheme depicted. The theater headquarters is established for unified operational direction.

b. The commander of the unified command may exercise *operational command* of assigned forces—(JCS Pub 2 and fig 2-1).

(1) Through the Service component commanders.

(2) By establishing a subordinate unified command (when authorized).

(3) By establishing a uni-Service force (when authorized).

(4) By establishing a joint task force.

(5) By attaching elements of one force to another force.

(6) By directing specific operational forces that, because of the mission assigned and the urgency of the situation, must remain immediately responsive to the commander. (When the theater mission is primarily directed toward the control of land areas and populations, the US theater commander, subject to approval by the Joint Chiefs of Staff and Secretary of Defense, will usually exercise operational command of Army combat forces—normally corps—in the combat zone.)

Section III. THEATER PLANNING

2-7. Basis for Theater Planning

a. The National Security Council formulates national security strategy for Presidential approval, and recommends national security policy and objectives. The Department of Defense, in coordination with other executive departments, translates national security strategy and objectives into national military strategy and strategic military objectives. The Joint Chiefs of Staff then consider both the recommendations of theater commanders and the total military capabilities of the nation to arrive at strategic plans that will accomplish the strategic military objectives.

b. The unified command commander receives strategic direction in the form of an approved strategic plan, a letter of instructions, or other orders from the President, Secretary of Defense, or Joint Chiefs of Staff. The basic strategic plan provides a strategic concept and specifies forces for each Service component. The strategic military objective assigned to the unified command commander will usually grant considerable latitude in the details of its

accomplishment. Based on these broad instructions, the commander of the unified command will formulate specific campaign plans for accomplishment of the strategic military objective.

2-8. Intelligence

a. The theater headquarters is primarily a strategic planning headquarters. To plan and prepare for the execution of assigned missions, the theater commander must possess timely intelligence of the enemy and the area of operations, the civil population, and related environmental factors. The collection of information and the production and dissemination of intelligence are continuing processes during peace as well as time of war.

b. The intelligence agencies of the Armed Forces and the Defense Intelligence Agency, in conjunction with the Central Intelligence Agency and the National Security Agency, produce intelligence on the capabilities, vulnerabilities, and probable courses of action of the armed forces of foreign nations and the other

forces that they may sponsor. They furnish timely warning of the nature of an impending attack on the United States, its forces abroad, and/or forces of friendly foreign nations. The agencies develop descriptive studies of foreign countries and potential theaters of operations. These studies provide a pool of basic intelligence.

c. Peacetime intelligence programs focus on the worldwide intelligence requirements for potential wartime combat purposes.

d. In wartime, the information collection effort focuses on existing and potential enemies. The unified command commander will require current intelligence concerning enemy dispositions, composition, capabilities, vulnerabilities, and probable courses of action, plus information concerning the area of operations and the local population.

e. The unified command commander provides overall direction and coordination of the intelligence effort of assigned forces. The Service component commanders maintain the means of executing their own intelligence functions; however, the unified command commander may establish an intelligence organization, composed of intelligence elements of all Service components under his operational command, to perform theater intelligence functions. When established, this organization also provides Service component forces with the intelligence required to supplement their own organic intelligence capability.

2-9. Scope of Theater Planning

a. The unified command commander plans as far in advance as possible and makes his operational and support needs known to Department of Defense through the Joint Chiefs of Staff. He projects his planning through the accomplishment of the strategic military objective by formulating campaign plans.

b. Campaign plans are normally prepared to cover long-range strategic missions, while operational plans are used for those missions of shorter duration or of lesser scope. Preparation of the campaign plan follows the long-range or strategic estimate of the situation. The purpose of the plan is to outline the strategic decisions made by the commander. The details and format of campaign plans are found in JCS Pub 2.

c. Decisive action results from clear-cut, comprehensive plans, based on full use of all available forces and means. If the commander foresees an unexpected opportunity for decisive action during the operation, plans are changed to exploit favorable developments.

2-10. Planning Considerations

a. The mission, political and economic constraints, relationships with the host country or allied nations in the area of operations, the enemy situation, attitude of the civilian population, climate, geography, local resources, transportation and communication facilities, base development, the psychological impact of military presence and activities, nature of operations, and forces available are key issues in the operational planning and organization of theater forces. An analysis of these factors facilitates territorial organization, the assignment of tasks, the allocation of forces, and development of the theater campaign plan.

b. Unified command headquarters planning is accomplished in conjunction with component force headquarters. The recommendations of component commanders are an integral part of theater planning.

c. Circumstances may permit forces to be employed against the enemy's industrial base to destroy his ability to wage war, thereby forcing him to areas of significant military disadvantage.

d. The commander may also be able to electronically isolate enemy units on the battlefield by seriously degrading their ability to communicate.

e. During the conduct of IDAD operations, a fixed line of contact is seldom defined, and the securing of objectives or terrain may have little or no significance. Usually, the primary objective is oriented on the population; therefore, the need for timely and accurate intelligence as a basis for planning is extremely important.

2-11. Planning by Subordinate Commanders

Theater plans provide sufficient guidance for the component forces to conduct operations that insure unity of effort. Therefore, theater plans affect the subordinate commanders by directing their efforts and defining the magnitude of tasks in terms of area, operational scope, and combat service support requirements. Subordinate commanders normally do not prepare orders and plans to cover the entire time span/scope of the campaign plan. They plan in detail for those initial actions for which necessary information is available and which they may be called on to execute early. For undertakings occurring later in the campaign plan, they conduct long-range planning. Figure 2-5 depicts how operational planning might be segmented at major operational echelons.

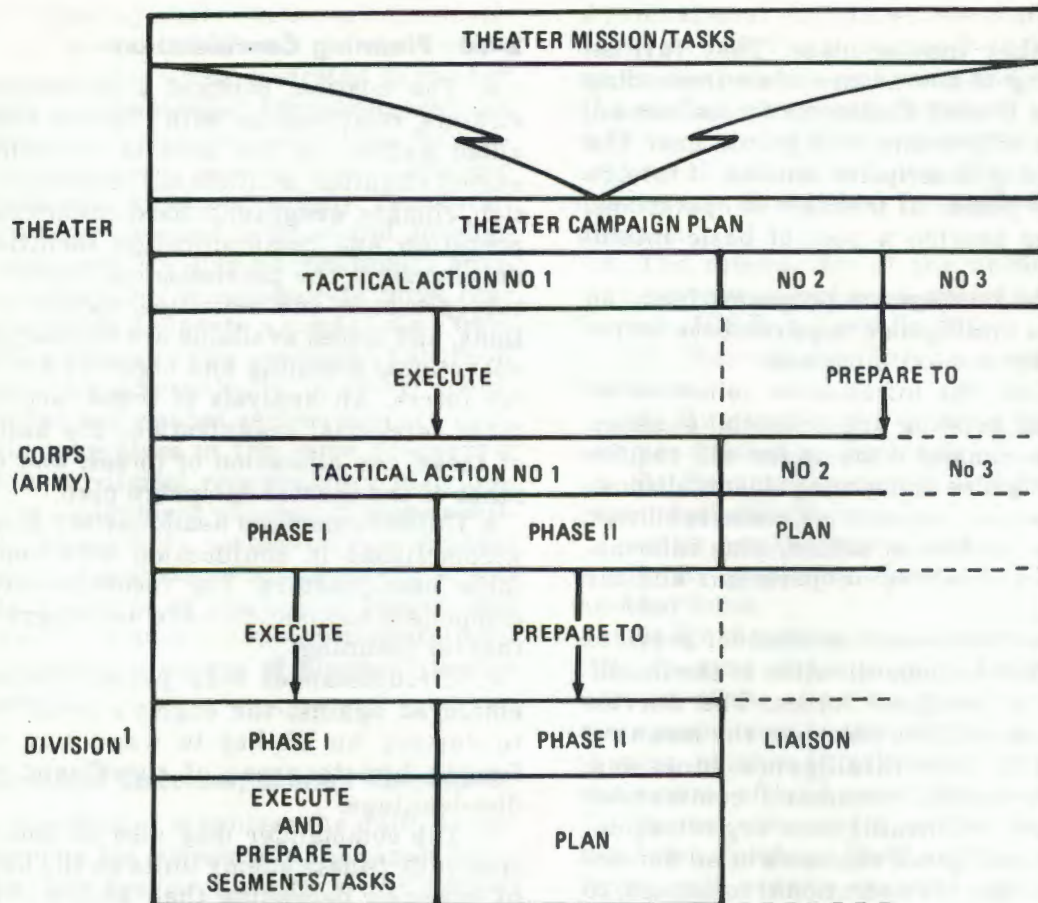

4-2000

¹In some situations the scope of the corps phase assigned to the division commander for execution may be of sufficient magnitude to prevent him from visualizing its completion. In these situations, the division commander may divide the operation into manageable segments for execution and planning. He would then assign the first such segment to his subordinate commanders for execution and assign the remaining segments to them for preparation.

Figure 2-5. Operational planning.

Section IV. OPERATIONAL CONSIDERATIONS

2-12. General

a. The principles discussed in this section pertain to the joint echelon of command providing operational direction and long-range planning guidance to multiple corps employed in an established theater. These corps will usually operate under a unified command, a subordinate unified command, a joint task force, or a combined force headquarters, hereinafter referred to as the joint command or joint headquarters.

b. In rare and unusual circumstances, a numbered army headquarters may be placed in the operational chain of command between the

corps and the joint headquarters. In such a situation, the principles outlined in this section also apply to that headquarters. Employment of a numbered army headquarters is further addressed in paragraphs 3-10 through 3-13.

2-13. Offensive Operations

a. *General.* Offensive operations normally require great impetus. Success is contingent on joint planning that effectively integrates joint resources; sufficient reserves of men, weapons, and materiel; and skillful decentralized execution of flexible plans that insure continuity of effort. FM 100-5 provides a fundamental discussion of offensive operations.

b. Missions to the Corps. Corps missions should be stated in broad terms to provide the corps commanders maximum flexibility and freedom of action. Assignment of specific terrain objectives should be avoided since they tend to inhibit initiative and restrict the corps commander's freedom of action.

c. Assignment of Corps Zones of Action.

(1) To facilitate control and to provide sufficient maneuver room and lines of communications (LOC) for each corps to execute its tactical plans, zones of action, designated by lateral and rear boundaries, are assigned by the next higher commander to delineate corps areas of responsibility.

(2) When establishing lateral boundaries for corps, the joint commander will focus attention on the major aspects of the terrain; e.g., major road nets, principal communication centers, large hill masses and mountain ranges, and significant obstacles. Major consideration must also be given to the capabilities and limitations of the units that constitute the corps, the nature of the enemy threat, and the level or intensity of the conflict. Once assigned, adjustment of corps boundaries is a matter of coordination between the corps and higher authority.

(3) Corps rear boundaries are established to provide sufficient room to employ the committed divisions, the corps reserve, the corps support command (COSCOM), and any theater army support command (TASCOM) combat service support unit that may be operating in the corps rear areas. In addition, since the corps rear boundaries separate the combat zone from the COMMZ, other considerations discussed in paragraph 2-5 must be taken into account.

d. Allocation of Combat Power.

(1) Corps will normally be structured, prior to deployment, based primarily on an analysis of the mission, enemy, terrain, and availability of forces, consistent with the principles of simplicity, austerity, realism, and flexibility. Accordingly, the initial allocation of combat power to the corps by the joint commander will be minimal. There may, however, be some separate unassigned maneuver and combat support units available to the theater commander. These units may be further assigned or attached to the corps, or they may be retained by the commander for employment in a reserve or rear area security (RAS) role. In either event, the allocation of available combat power will complement the commander's concept of the operation and provide sufficient forces to allow the corps commanders to accomplish their assigned missions.

(2) Ideally, the joint commander will maintain a maneuver reserve with which he can influence the action. When a maneuver reserve is maintained, it will normally be passed to the corps in whose sector the reserve is committed. The joint commander may also retain nuclear weapons in reserve. FM 100-5 provides a fundamental discussion of the elements of combat power.

e. Offensive Maneuver.

(1) The joint commander must maneuver his corps in such a manner as to impose his will on the enemy, creating conditions that permit him to gain an advantage over the enemy and insure accomplishment of the strategic objective. These major offensive actions may be oriented against the front, flank, or rear of the enemy, employing the corps in one or a combination of the forms of maneuver. There are three basic forms of offensive maneuver:

- (a) Penetration.
- (b) Envelopment.
- (c) Frontal attack.

The double envelopment and turning movement are variations of the envelopment.

(2) The selection of a form of maneuver by the joint commander is influenced by an analysis of the strategic objective; geography; population; degree of urbanization; climatic conditions; available time; disposition and capability of available forces; ability to support the operation; and the disposition, composition, and strength of the enemy force.

(3) The joint commander will rarely specify the form of maneuver to be employed by the corps. However, the assignment of missions, zones of action, and the combat power available to the corps may impose limitations or create conditions that dictate the adoption of a specific form of maneuver. Chapter 4 provides additional discussion of offensive maneuver and the types of offensive operations.

2-14. Defensive Operations

a. General. Planning and conduct of large-scale defensive operations employing two or more corps must be centrally coordinated by the headquarters providing operational direction to the corps. Each corps will normally be given responsibility for defending a portion of the forward edge of the battle area (FEBA) by assigning it a specific sector. As in the offense, the preponderance of available maneuver units will be allocated to the corps. A detailed discussion of defensive operations is provided in chapter 4.

b. Missions to the Corps. Corps missions are stated in broad terms that provide the corps

commanders maximum latitude in the development of their plans. The operational headquarters next above corps will prescribe the general trace of the FEBA, designate corps boundaries, and task each corps to defend its assigned sector. The decision concerning the form of defense and the employment of security forces will normally be left to each corps commander.

c. Assignment of Corps Defensive Sectors.

(1) Limitations on available forces or responsibility for extended frontages may require the joint commander to determine where he must defend in strength and where he can employ economy of force measures. A detailed analysis of the terrain, enemy situation, and own capabilities provides the basis for the assignment of defensive sectors to each corps.

(2) Enemy avenues of approach that permit the unrestricted maneuver of the major combat elements of one or more enemy divisions will normally be assigned to a single corps.

d. Allocation of Combat Power.

(1) The joint commander will visualize how each corps might defend its assigned sector by comparing the capabilities of each type division in the corps with the terrain and expected enemy threat. This visualization may result in the shifting of forces between corps to achieve the best possible balance and mix of combat power.

(2) In the defense, as in the offense, it is desirable to retain a reserve with which the joint commander can influence the battle at critical times and places.

e. Employment of the Reserve.

(1) When the joint commander retains a maneuver reserve, it should be positioned where it can best influence the action. If, for example, the joint commander is able to identify one corps sector as the most critical, the reserve will normally be located in that corps' area.

(2) The reserve will normally be released to a corps for commitment. The joint commander will analyze the situation and determine, in priority, likely threats to vital areas. Plans are then formulated to release the reserve for those assumed penetrations that are beyond the capability of the corps commander. Additionally, if nuclear or conventional fires destroy major elements of the corps prior to engagement with major enemy forces, it may be necessary to release part of the reserve to the corps.

2-15. Retrograde Operations

a. General. During a retrograde operation, forces may conduct a combination of withdrawals, delaying actions, and retirements. The

basic purpose of a retrograde operation is to preserve the integrity of the command for future operations; however, it can be employed for other reasons; e.g., to reposition forces on more defensible terrain or to eliminate a vulnerable salient. Chapter 4 contains a discussion of retrograde operations at the corps level.

b. Planning and conduct of retrograde operations.

(1) The joint commander will normally develop the plan for a retrograde operation involving more than one corps. Such a plan may include phasing, designation of withdrawal sectors, starting time, closing time on the new defensive positions, and allocation of forces to each corps.

(2) The majority of available forces will be attached to the corps during retrograde operations. TASCOM units, as required, may also be attached to the corps. Because of the decentralized execution of retrograde operations, the joint commander retains minimum forces under his direct control. The detailed planning and tactical execution of retrograde operations are accomplished by the corps and lower echelons.

2-16. Other Operations

a. Electronic Warfare Operations. Electronic warfare is integrated into operational plans at the highest command echelons. It is used to support other operations and functions, including cover and deception, intelligence, target acquisition, security, and command and control. It can be employed to detect enemy command locations, reduce the enemy commander's control, or mislead him by transmitting deceptive data. Use of electronic warfare measures must continually be evaluated from both the tactical and strategic level. For example, the value of intelligence obtained from enemy communications may outweigh the immediate tactical advantage of jamming the communications. Detailed discussions of electronic warfare are provided in FM 32-10, FM 32-20, AR 105-2, AR 10-122, and AR 105-87.

b. Cover and Deception.

(1) Large-scale operations are both joint and strategic. The theater commander may develop strategic cover and deception plans to support strategic objectives. Deception is strictly controlled to insure compliance with national policies.

(2) Cover and deception operations require coordination with other Services and with allied commanders. Properly conceived and employed, cover and deception tactics will deceive the enemy as to the true dispositions, capabilities,

ties, or intentions of friendly forces. Cover includes special measures designed to provide security to a plan, operation, or activity as well as intensifying normal security and passive defense measures. Deception is an activity designed to mislead the enemy by manipulating, distorting, or falsifying evidence.

c. Denial Operations.

(1) Denial operations include those actions taken to prevent or hinder the enemy's use or benefit from areas, personnel, facilities, or materiel. They may include destruction, removal, contamination, or erection of obstructions.

(2) Subject to the limitations imposed in directives from higher authority and the availability of time and resources, the joint commander establishes the theater policy governing denial operations. The joint commander may conduct denial operations as a part of his overall campaign. His denial plan provides information on specific targets to be denied, the degree of denial desired, the priority of preparation and execution, and the subordinate commander responsible for planning and execution.

d. Barriers.

(1) Barriers are a coordinated series of natural and artificial obstacles employed to canalize, direct, restrict, delay, or impede the movement of an opposing force and to impose additional losses in personnel, time, and equipment. A barrier ordinarily links natural and artificial obstacles in a linear form, but is not an impenetrable line of great depth and continuous strength.

(2) The joint headquarters will prepare broad barrier studies that consider weather and the obstacle value of the terrain relative to planned operations. Based on these studies, and the strategic denial plan, the joint commander will publish a single, coordinated barrier and denial plan. This plan provides the strategic barrier and denial concept that will serve as a coordinated framework around which the corps can develop their plans.

e. Other Operations. The theater commander will usually provide unified direction for air defense, unconventional warfare, and psychological operations. The degree of centralized direction over these operations may vary from policy guidance to the establishment of major subordinate multi-Service commands. Army doctrine for each type of operation is addressed separately in succeeding chapters beginning at the theater army level.

2-17. Operations in a Nuclear Environment

a. Nuclear Weapon Allocation and Assign-

ment. Once he has received authority to employ nuclear weapons, the joint commander will allocate and assign nuclear weapons for a specific period of time or phase of an operation or to accomplish a particular mission. An *allocation* is the specific number and type of nuclear weapons that the subordinate commander may plan to expend during the time period or operation specified. The allocation is for planning purposes only and does not include authority to expend. An *assignment* constitutes the authority to expend a specific number and type of nuclear weapons during the time period or operation specified. Allocations and assignments are made to supported commanders (not to supporting delivery units), but do not imply responsibility for securing, maintaining, or transporting the weapons. A commander may be allocated or assigned nuclear weapons that will be delivered for him by units not under his command or control.

b. Special Ammunition Load and Stockage.

The special ammunition load (SAL) is a specific number of nuclear rounds to be carried by each appropriate delivery unit. The SAL is based on the unit's ability to transport and deliver the weapons and on the tactical situation. The establishment and replenishment of each SAL is a command decision. Loads may vary from day to day among like delivery units. A SAL implies responsibility for security, transportation, and proper delivery of the weapons, but no authority to expend or to plan for expenditure. The special ammunition *stockage* (SAS) includes the specific number and types of nuclear rounds to be stocked by each appropriate ammunition service unit (special ammunition supply point or depot). The establishment and replenishment of each SAS is a command decision. Stockages may vary from day to day among like supply points or depots. A SAS implies responsibility for security, transportation, and issue (transfer to a SAL by proper authority) of the weapons, but no authority to expend or to plan for the expenditure of the rounds stocked. All of the nuclear weapons within the theater can be accounted for by their presence in the SAL of a delivery unit or in the SAS of an ammunition service unit within the theater.

c. Dispersion. During nuclear operations, battlefield dispersion will be commensurate with the level of nuclear weapon use. The theater commander will be concerned with the adequacy of space provided by existing tactical, geographical, or international boundaries. Transition to an active nuclear environment may require shifting corps lateral boundaries; however, rearward or forward movement to

achieve dispersion may prove more practicable than lateral movement. The unrestricted use of nuclear weapons can seriously reduce the relative significance of maneuver as an expression of combat power. During such a period of high intensity, which could continue until the enemy's tactical nuclear capability has been neutralized within the theater, dispersion will help insure the survival of friendly maneuver forces until they can be effectively employed once again. Concurrent with the requirement for additional dispersion is the increased need for redundancy of command and control systems.

d. Communications. Electromagnetic phenomena created in the atmosphere by nuclear

detonations will cause temporary interference with electronic communications and permanent damage by electromagnetic pulse to certain components of communications as well as other types of electronic equipment. Commanders at all echelons must anticipate the loss of electronic communications and the requirement to operate semi-independently in the absence of tactical direction or guidance. The use of alternate means of communication should be planned and other means of command and control (such as plans and orders, standing procedures, organization for combat, training and discipline) will become more important in this environment.

DOCTRINAL RECAPITULATION

- The Joint Chiefs of Staff are the principal military advisers to the President, the National Security Council, and the Secretary of Defense.
- The Chief of Staff, US Army, is directly responsible to the Secretary of the Army for the efficiency of the Army, its state of readiness for military operations, and the plans therefor.
- Unified or specified commands are established on an area or functional basis by the President through the Secretary of Defense with the advice of the Joint Chiefs of Staff.
- The chain of command for the strategic and operational direction of US forces runs from the President to the Secretary of Defense, then through the Joint Chiefs of Staff to the commander of the unified command.
- With the advice of the Joint Chiefs of Staff and subject to the approval of the Secretary of Defense, the US unified command commander will normally exercise operational command of US Army combat forces (normally corps) during wartime, while the theater army commander retains command less operational control of such forces.
- With the approval of the Joint Chiefs of Staff, the commander of a unified command may establish a uni-Service force that will operate directly under him.
- A subordinate unified command may be established by the commander of the unified command with the concurrence or at the direction of the Joint Chiefs of Staff with the consent of the Secretary of Defense.
- A joint task force is a force composed of elements of two or more Services that may be established by the Secretary of Defense, unified command commander, specified command commander, or the commander of an existing joint task force.
- The unified command commander has directive authority in the field of logistics to provide for common-servicing, joint-servicing, or cross-servicing agreements or assignments.
- The organization of a combined command, to include command relationships, is established by international treaty agreement.
- The US component of a combined command may be a unified command, a specified command, a joint task force, or a uni-Service force.
- The National Security Council formulates national security strategy for Presidential approval and recommends national security policy and objectives.

- The Department of Defense translates approved national security strategy and objectives into national military strategy and strategic military objectives.
- The Joint Chiefs of Staff consider total military capabilities and the recommendations of theater commanders to develop strategic plans that will accomplish the strategic objectives.
- The mission assigned to a unified command commander, based on a strategic plan, is usually broad in nature and provides him considerable latitude in its accomplishment.
- Initial plans at unified command level include base development, command and control facilities, and force structure.
- Unified command plans provide sufficient guidance for the component forces to conduct operations and insure unity of effort.
- The unified command commander establishes the boundary between the combat zone and the communications zone based on the recommendation of the theater army commander, in coordination with other Service component commanders, and with the advice of the corps commanders.

4-1. Mission

The theater army is the Army component of the unified command in a theater of operations. Its primary mission is to organize, equip, train, and employ US Army forces to support the strategic goals of the unified command.

In time of war, the theater army commander exercises command and control of all Army forces, less operational control of his corps and other Army elements that are assigned directly under the operational command of the unified command commander or a higher designated headquarters. In addition, he may exercise the theater army commander's war control and administrative control over all Army forces.

In peacetime, the theater army commander exercises command and control, in a theater of operations, of all the Army forces of the United States Army in direct support of the theater army commander's mission. The theater army commander is responsible for operations, training, and logistics for all Army forces, and for their maintenance in contingency situations. Part of his war control and administrative control of the theater army forces is exercised in the theater commander's command or other designated headquarters in time of war.

4-2. Command relationships

a. General. The theater army commander is assigned and qualified by the Department of Defense and the Army Department to carry out his mission in the theater army command, which is an Army force, and is a temporary force or force of forces as directed by higher authority in the theater army

commander and the theater army commander. When he receives and interprets his mission, he organizes and directs his headquarters and staff to execute the functions of command and control assigned to him. The theater army commander's mission is to be executed through a deputy.

b. Relationship with the commander of the Unified Command. The theater army commander is responsible for the execution of his mission and for the accomplishment of those missions and functions assigned to him by the unified command and other agencies that may be assigned. He exercises command and control over all Army forces assigned to him by the unified command commander and the theater army commander.

c. Staff. The theater army commander's staff is organized and directed to execute the theater army commander's mission. The theater army commander's staff includes administrative, personnel, training, logistics, communications, intelligence, medical, dental, veterinary, and maintenance matters, security of Army forces.

d. Relationship with Component Commanders. The theater army commander exercises his operations and administrative functions through the theater army commander and other designated headquarters. The theater army commander is responsible for the execution of his mission through the theater army commander.

4-3. Theater Army Headquarters Organization

The theater army headquarters is a TDH and is organized as follows:

CHAPTER 3

MISSION, ORGANIZATION, AND FUNCTIONS

OF ARMY ECHELONS ABOVE CORPS

Section I. THEATER ARMY MISSION AND ORGANIZATION

3-1. Mission

The theater army is the Army component of the unified command in a theater of operations. Its mission is to organize, equip, train, and provide US Army forces to support the requirements of the unified command.

a. In time of war, the theater army commander exercises command of all US Army forces, less operational control of the corps and other Army elements that may be held directly under the operational command of the unified command commander or other designated headquarters. In unusual wartime situations the theater army commander may be given operational control over all Army forces.

b. In peacetime, the theater army commander normally will exercise command, including operational control, of all US Army forces in the theater except Army air defense artillery, US Army Communications Command, and US Army Security Agency elements. The theater army commander is responsible for operational and contingency planning, as well as administration and logistics, for all Army forces, and he must be responsive to contingency situations. Plans are made to transfer operational command of the corps and other Army elements to the unified command commander or other designated headquarters in time of war.

3-2. Command Relationships

a. General. The senior US Army officer assigned and qualified for command by law and Army regulations is normally designated the theater army commander. Only in an emergency and on a temporary basis, or when directed by higher authority, is the theater army

commander also the unified command commander. When he exercises dual command, he uses separate and distinct headquarters and staffs to exercise the functions of operational command and component command. The component command functions would be exercised through a deputy.

b. Relationships With the Commander of the Unified Command. The theater army commander is responsible to the unified command commander for effective accomplishment of those missions and functions inherent in Service component command and such missions that may be assigned. He makes recommendations to the unified command commander and other Service components on the most effective use of Army forces.

c. Relationship With the Department of the Army. The theater army commander communicates directly with Headquarters, Department of Army, on uni-Service matters relating to administration, personnel, training, logistics, communications, doctrine, combat developments, and intelligence matters primarily of Army interest.

d. Relationship With Collateral Commands. The theater army commander coordinates his operations with those of the Navy component, Air Force component, and other major subordinate commands of the unified command (fig 2-1). The theater army commander provides combat service support to the Army component and other Service components as directed.

3-3. Theater Army Headquarters Organization

The theater army headquarters is a TDA unit and has no fixed organization. It is structured,

organized, and staffed to meet the varied missions and requirements of the theater army. The number of personnel required depends on the size of the Army component; environmental factors; level, complexity, and scope of operations; availability of resources; and desires of the commander (fig 3-1).

3-4. Theater Army Staff

a. General. The theater army headquarters (TAHQ) uses a coordinating staff to assist the commander in accomplishing his mission. Staff activities normally concern policy, long-range planning, priorities, and coordination rather than current operations. In time of war, the staff will be concerned with combat support, combat service support, and administration of all US Army forces and such other forces or components as the theater commander may designate.

b. Other Staff Functions. Information officer, inspector general, and staff judge advocate functions, not integrated into the coordinating staff, are performed either by separate staff sections or by personnel assigned to the commander's personal staff. FM 101-5 provides a discussion of staff officer functions.

c. Tactical Operations Center. In most cases,

echelons above corps do not have a tactical operations center, because they are engaged primarily in long-range planning and are not extensively involved in day-to-day operations. However, a command operations center (COC) is established to provide the commander with communications between the unified command headquarters, higher authorities, and subordinate elements.

3-5. Territorial Responsibility (US Theater)

a. The territorial organization of a theater of operations is described in paragraph 2-5 and figure 2-4 of this manual. Responsibility of US Army elements for this area is assigned after coordination with other service components and allied forces and is dependent upon the nature of operations and stage of theater development. In the area of IDAD operations or during the conduct of contingency operations of short duration, the theater territorial organization will not normally fix corps rear boundaries and delineate a combat zone from a COMMZ. Rather, territorial responsibility will be assigned for areas of responsibility (AOR) and support bases and/or terminal facilities.

b. In a developed theater, the theater army commander, after coordination with other com-

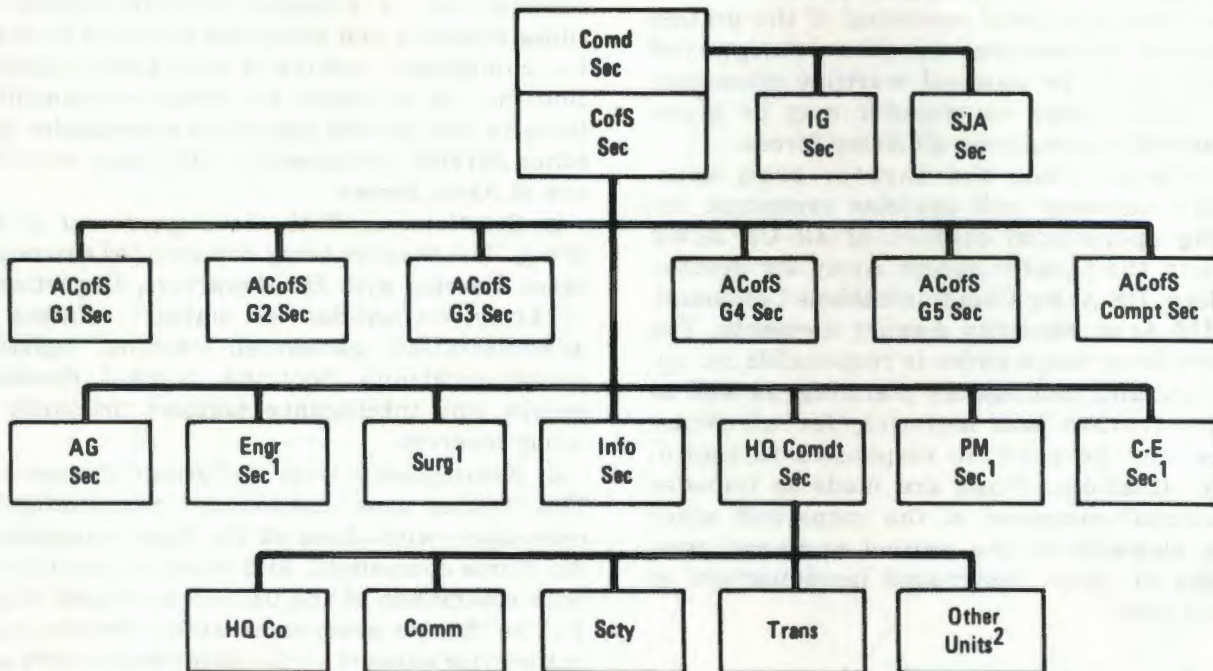

¹Special staff officer or section may be assigned to major subordinate command/element.

²As required.

Figure 3-1. Illustrative theater army headquarters.

ponent commanders and with the recommendations of the corps commanders, recommends the location of the corps rear boundaries. Security in the combat zone, to include rear area protection (RAP), is the responsibility of the respective corps commanders. The corps commanders will normally task their respective COSCOM commanders to plan for and direct

RAP activities in assigned areas.

c. The theater army commander will normally assign RAP responsibility to the theater army support command (TASCOM) commander for the Army's area of responsibility within the COMMZ. Combat forces may be provided when RAP requirements exceed the capabilities of forces available to the TASCOM.

Section II. THEATER ARMY FUNCTIONS

3-6. General

a. The theater army organization is structured to accomplish its assigned missions. The functions of the theater army can be divided into two broad categories: support of unified command plans and Service component support.

b. The theater army commander is responsible for Army plans and forces to support unified command plans and operations in—

- (1) Land combat.
- (2) Intelligence.
- (3) Psychological operations.
- (4) Civil affairs operations.
- (5) Unconventional warfare.
- (6) Theater air defense.
- (7) Cover and deception and electronic warfare operations.
- (8) Special ammunition support, when directed.
- (9) Combat service support to other Service components and allies, as directed.

c. Theater army component functions are—

(1) Internal administration and discipline except where those functions are of joint interest or in cases where the unified command commander reserves authority at his headquarters.

(2) Training in Army doctrine, tactics, techniques, and procedures.

(3) Enemy prisoner-of-war and captured US Army personnel policy and planning matters.

(4) Employment of forces placed under the operational control of theater army by the unified command commander.

(5) Combat service support to Army forces. The theater army commander operates the Army combat service support system in accordance with Department of the Army instructions, subject to the directive authority of the unified command commander concerning—

(a) Assignment of priorities.

(b) Acquisition, storage, movement, distribution, maintenance, evacuation, and disposition of materiel.

(c) Movement, hospitalization, and evacuation of personnel.

(d) Acquisition or construction, maintenance, operation, and disposition of facilities.

(e) Acquisition or furnishing of services.

3-7. Combat Support

a. *Intelligence.*

(1) In peacetime, the theater army commander is responsible for overall direction and coordination of the Army intelligence effort as directed by the theater commander. This effort involves collecting and processing information and disseminating intelligence and counterintelligence, including technical, scientific, and target intelligence, and is coordinated with other Service components as necessary. The theater army commander tasks subordinate commanders with intelligence missions.

(2) During wartime, the unified command commander may require that elements of the theater army intelligence organization be placed under his operational command. Included among these intelligence units may be signal intelligence (SIGINT) elements whose activities may be directed toward strategic objectives. In these instances, the unified command commander coordinates these activities with the JCS and the National Security Agency (NSA). The theater army commander is tasked with organizing, training, providing and supporting the Army intelligence elements not organic to the corps.

b. *Theater Army Communications.*

(1) *Theater army responsibilities.*

(a) The theater army commander provides for communications services to Army elements and to other Services and agencies as directed. The theater army staff plans, coordinates, and supervises the formulation and implementation of communications-electronics plans, policies, and procedures for installation, maintenance, operations, and management of Army communications service in support of theater and theater army command and control requirements.

(b) Communications-electronics services are provided to all Army forces in the theater of operations. In the combat zone, signal elements assigned to the corps provide a command communications system linking the corps headquarters with their major subordinate elements, and an area communications system for support of those assigned, attached, and supporting units having no organic communications capability. In the COMMZ, communications services are established and provided by the theater army communications command, which also provides communications to, but not within, the corps.

(2) *Theater army communications command.*

(a) The theater army communications command (TACCOM), a subordinate element of the US Army Communications Command (USACC), installs, maintains, and operates the theater army communications system (TACS). Operational control of the TACCOM is exercised by the theater army commander. The TACCOM commander may serve on the theater army commander's staff. The TACCOM provides internal communications for headquarters and installations in the COMMZ that do not have organic communications elements; (e.g., mission commands, theater army support command (TASCOM)); interface points that interconnect communications systems in the combat zone and the TACS; and such other communications support as may be directed. Other support may include support to the theater headquarters, operation of assigned portions of the defense communications system (DCS) in the theater of operations, and inter-Service or interagency support.

(b) The organization of each TACCOM will be designed to support a specific force structure in a specific theater of operations.

(3) *Theater army communications system.* The theater army communications system (TACS) consists of a multimeans, multiaxis, integrated network extending from the rear of the theater, through the COMMZ, and interfacing with the communications systems of the combat zone. The TACS is a part of and must interface with the defense communications system (DCS) at theater access points. The TACS, composed of long lines, radio and cable trunking systems, communications centers, patching and switching facilities, and multichannel access systems, varies in composition and magnitude from one theater to another depending on operational considerations. Details on the TACCOM and the TACS are contained in FM 11-23.

(4) *Communications security logistic support.* Communications security (COMSEC) logistic support for the Army in the theater is provided by the TACCOM. Organic COMSEC logistic support units (CLSU) are placed in direct support (DS) and general support (GS) of Army units throughout the theater. CLSU may be attached to the COSCOM for administrative support in the combat zone.

c. *Army Air Defense.*

(1) *General.* Air defense of a theater is a joint effort that integrates the total air defense resources of all theater components under the direction of a *single air defense commander*. Authority for execution of operations is decentralized as necessary to best accomplish the air defense mission. Regardless of the authority delegated to subordinate commanders, the principle of unity of effort and responsiveness to a *single air defense commander* is followed (fig 3-2).

(2) *Organization and responsibilities (US Theater).*

(a) *Unified command commander.* The unified command commander is responsible for air defense of the theater. He will establish priorities, allocate air defense resources, and appoint a single commander for area air defense, normally the Air Force component commander. Based on the recommendations of the area air defense commander, the unified command commander will establish broad theater air defense policies and procedures that govern the employment of all theater air defense systems and resources. The unified command commander may assign the corps commanders responsibility for the air defense of their respective areas. In this case, he allocates the necessary weapons and forces for them to establish a defense and delegates the authority (subject to air defense rules and procedures) necessary for instantaneous reaction to hostile air attack. If the unified command commander places most of the corps' air defense artillery under the operational control of the area air defense commander, the area air defense commander assumes responsibility for air defense of the area for which the unified command commander otherwise holds the corps commander responsible. In either case, the unified command commander is responsible for final determination of air defense priorities and the allocation of air defense means thereto.

(b) *Area air defense commander.*

1. The area air defense commander is responsible to the unified command commander for coordination and integration of the

entire air defense effort. Subject to the approval of the unified command commander, he will publish policies and procedures for the coordination and employment of all theater air defense means. Representation from each Service component with air defense resources will be provided to the area air defense command post.

2. When a significant portion of the air defense means is contributed by a service other than that of the area air defense commander, that service will appoint an officer to serve as deputy to the area air defense commander. This concept is also applicable to regional air defense commands.

3. The area air defense commander normally will establish air defense regions and appoint regional air defense commanders. The number and size of such regions will vary depending upon geographical and political factors; the hostile threat; complexities of the air defense problem; the disposition, composition, and capabilities of friendly forces; the theater campaign plan; and the unified command concept of operations.

(c) Regional air defense commanders.

1. The regional air defense commander is given authority and held fully responsible for air defense in his region. However, in the combat zone, air defense artillery assigned or attached to the corps will normally remain under the operational control of the corps commanders, subject to the theater air defense rules and procedures. All air defense systems and means located in the COMMZ are habitually placed under the operational control of the regional or area air defense commander.

2. The regional air defense commander will promulgate the air defense rules and procedures that govern the employment of all air defense units operating within regional boundaries, to include those air defense resources that may be under the command or operational control of the corps commanders. These rules and procedures may include the conditions of readiness, air defense and nuclear warnings, rules of engagement, weapons control status, hostile criteria, and rules for initial release of nuclear weapons and nuclear warhead selection. The rules and procedures also may include special control instructions, certain coordinating and reporting instructions, and the direct coordination and information exchange links required between and among control facilities and the regional air defense control facilities.

(d) Operational considerations. The Army component commander usually commands US Army elements during peacetime and exercises

command less operational control of Army combat and combat support elements during wartime. The operational control of air defense artillery units during peacetime is commonly an exception to this policy. In time of peace, air defense operations are characterized by a 24-hour-a-day vigil. Control and coordination measures must be established prior to the outbreak of hostilities to insure engagement of all hostile aircraft, to prevent engagement of friendly aircraft, and to minimize mission interference. Air defense rules and procedures must be promulgated so that the transition to war conditions and instantaneous reaction to hostile attack can take place without confusion or delay. This requires that the air defense resources of each Service be coordinated and responsive to a single air defense commander at all times. Accordingly, all or part of the nondivisional Army air defense units in a theater will normally be integrated into the theater air defense system. Training and maintenance of these units necessary to insure prompt and effective reaction to the hostile threat remain an Army component responsibility.

d. Psychological Operations.

(1) Psychological operations (PSYOP) are employed to influence behavior in achieving national objectives. PSYOP elements assigned to the theater army and not further attached to Army combat forces or other subordinate commands may be held under operational command of the unified commander to insure unified direction. These Army elements engage in strategic and consolidation PSYOP and operate in and from the COMMZ.

(2) Army combat forces are concerned primarily with tactical PSYOP designed to produce short-term results. These operations are conducted within the broad plans and policies established by the unified commander. FM 33-1 provides detailed discussion of PSYOP activities in support of tactical and strategic objectives.

e. Unconventional Warfare Operations.

(1) Unconventional warfare (UW) includes the interrelated fields of guerrilla warfare, evasion and escape, and subversion. UW operations are conducted in enemy, or enemy controlled territory by predominantly local personnel. They are usually supported and directed in varying degrees by an external source and may be conducted during conditions of either war or peace. UW operations may be either strategic or tactical in nature and are conducted primarily to assist and support the conventional military effort. To produce the desired effect, UW operations should be sup-

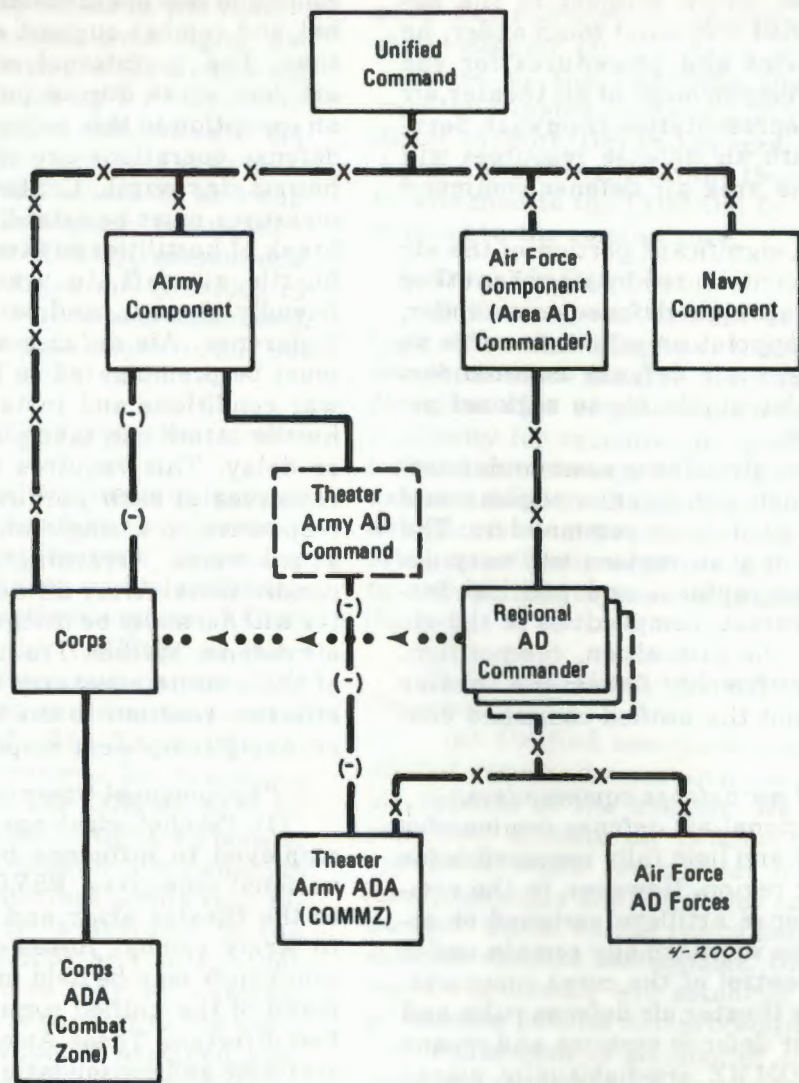

LEGEND

- Command.
- X—— Operational command (operational control).
- (-)—— Command less operational control.
-<..... Air defense rules and procedures.
- [- - -] When required for coordination of administrative and logistic support of tactical units.

¹May be under operational control of the regional AD commander.

Figure 3-2. Illustrative unified command air defense structure.

ported by psychological operations (PSYOP) designed to influence the target population and by civil affairs operations designed to reintroduce a governmental capability.

(2) When a theater UW command is established, the Special Forces (SF) element is the Army component of the UW command. The SF element will normally establish special forces

operational base(s) (SFOB) in friendly territory from which it plans, controls, directs, and supplies SF operations in hostile areas. In a conventional warfare situation, SF units operating within the area of influence of the advancing tactical command will be under the operational control of that tactical command, i.e., corps or division. Special forces units can undertake a

variety of special missions under circumstances and in environments not customarily envisioned for conventional forces. SF operations may be either in a primary or supporting role, unilaterally, or in conjunction with other forces or agencies. FM 31-21 and FM 31-21A provide detailed discussion of SF operations. Additional discussion is in chapter 4 of this field manual.

f. Internal Defense and Development (IDAD)

(1) Internal defense and development operations and assistance encompass the strategies and techniques to prevent or defeat insurgent war. Internal defense is the full range of measures taken by a government and its allies to free and protect its society from subversion, lawlessness and insurgency. Internal development is defined as actions taken by a nation to promote its balanced growth by building viable institutions—political, economic, and social—that respond to the needs of its society, thus reducing the conditions that foster insurgency.

(2) The US military objective in internal defense is to neutralize the insurgent threat by increasing the capability of the host country military, paramilitary and other security forces to restore and maintain order, while concurrently degrading the insurgent capability to disrupt order. The theater army will provide assistance as directed by the unified command. In internal defense this assistance may include advisory, civil affairs, psychological, intelligence, police, population and resources control, and tactical operations. To aid the internal development of the host country, theater army may be required to provide technical assistance and logistic support. US Army forces serve under the guidance of the Chief, US Country Team, and their efforts are integrated with those of other Services and US government agencies. Details concerning employment of US Army forces in IDAD are contained in FM 19-50, FM 31-16, FM 31-23, FM 31-73, FM 33-1, FM 33-5, and FM 41-10.

3-8. Combat Service Support

a. The theater army commander retains the overall control of combat service support operations to insure responsiveness of the support effort within the theater. He develops the administrative/logistics plans and orders to support the theater campaign plan. He exercises control by issuing appropriate policies, mission directives, broad planning and program guidance, allocations, and priorities for accomplishing the theater army mission.

b. The dominating aspects of combat service support and the requirements for economy and austerity will demand highly skilled and disci-

plined execution of these functions using advanced concepts in strict accordance with principles that enhance cost effectiveness. These principles apply whether a force is conducting extended operations in an established theater or short duration contingency operations and include the following:

(1) Use of the most advanced materiel management systems to achieve intransit and intratheater asset visibility, and at the same time reduce manpower and materiel requirements.

(2) Use of direct supply support system to provide rapid response to supply requirements, bypassing intermediate supply complexes when possible.

(3) Limitation of in-theater stockage.

(4) Facilitate in-theater maintenance through increased use of the "repair by replacement of modules" concept at both the organizational and direct support levels.

(5) Tailoring in-theater general support maintenance capabilities to perform only repairs required on critical items of equipment and, concurrently, relying on maintenance capabilities external to the theater for "noncritical" general support.

(6) Maximum reliance on air lines of communication (ALOC) using strategic and tactical airlift delivery as far forward as possible.

(7) Use of the most advanced communications systems, including satellite communications, between operating units and inventory control points to replace critical items.

(8) Adherence to the shortest practical medical evacuation policy.

(9) Adherence to a policy of only minimum essential base development and other construction.

(10) Reduction of storage operations by utilizing throughput distribution, improved handling techniques, specialization of labor, pre-packaging, and palletization of container insert loads for unit distribution.

(11) Establishment and rigid enforcement of an austere standard of living within the theater of operations.

c. A TASCOM is organized when a communications zone is envisioned. TASCOM provides the following combat service support to Army and other designated forces in a theater of operations:

(1) General support to forces in the combat zone.

(2) Direct and general support to forces in the communications zone.

d. TASCOM headquarters accomplishes its mission through functional subordinate organi-

zations. (fig 3-3). TASCOM executes the combat service support functions to include personnel and administrative services, labor, supply, maintenance, transportation, hospitalization and evacuation, construction, and civil affairs for the operating forces. TASCOM issues technical instructions to, and conducts technical inspections of, supported organizations of theater army.

e. Because of the magnitude and diversity of the engineer tasks, which include the provision of real property maintenance activities (RPMA) support throughout the theater, the theater army commander may centralize engineer assets under his operational control. He may likewise elect to maintain centralized control of civil affairs operations.

3-9. Rear Area Protection (RAP)

a. The purpose of RAP is to prevent interruptions to combat support and combat service

support operations. It includes all actions taken to counter enemy threats to units and to reduce damage to activities and installations. It is an organized extension of the local security and damage control that is established by the unit or installation commander. RAP is divided into two separate functions—

(1) Rear area security (RAS): measures taken to minimize the effects of enemy attack, sabotage action, or infiltration guerrilla action.

(2) Area damage control (ADC): measures taken before, during, or after hostile action or natural or manmade disasters to reduce the probability of damage and minimize its effects.

b. The TASCOM commander is routinely responsible for RAP of the COMMZ (less any land or water areas otherwise assigned). The TASCOM may be organized with one or more area commands, in which case the TASCOM commander normally delegates authority for per-

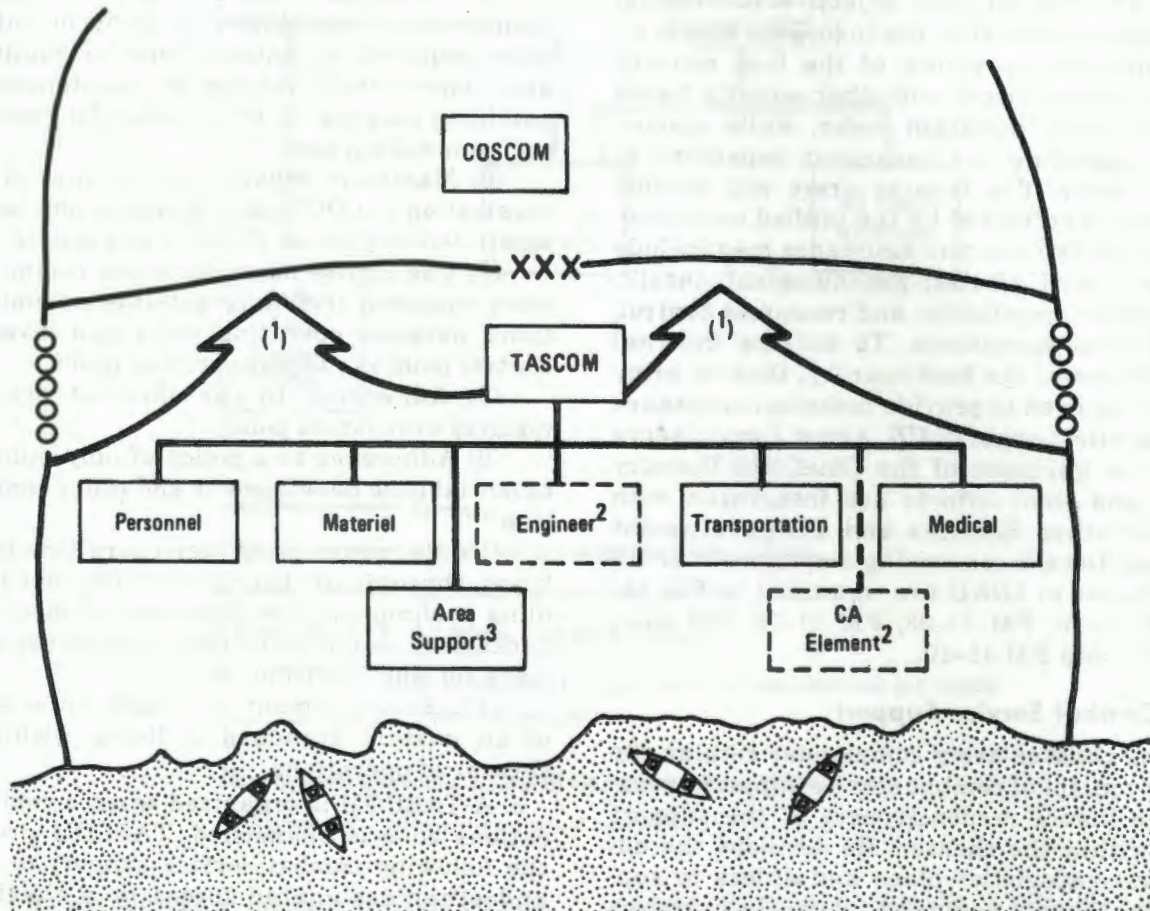

¹ Combat service support (CSS) to the combat zone.

² May be directly under TA control.

³ Provides DS combat service support in the COMMZ.

Figure 3-3. TASCOM.

formance of the RAP mission to these elements. When employed, the area command is a major subordinate command of the TASCOM

and is responsible for support of US Army forces and designated units of other Services in the COMMZ.

Section III. THE NUMBERED ARMY HEADQUARTERS

3-10. General

In wartime, the next operational echelon above the corps normally will be a unified command, or a joint task force. There may be unusual wartime operational circumstances that require an Army echelon between the corps and the unified headquarters. Such circumstances include span of control considerations, widely dispersed formations of significant forces, political or geographical considerations, and variations in the enemy threat or environments. When such a requirement exists, a *numbered army* will be formed and employed as an intermediate operational headquarters between the corps and the unified command, as an exception to the normal operational command relationship.

3-11. Command Relationships

The theater army commander will exercise command, less operational control, of the numbered army headquarters and all Army forces placed under the operational direction of the numbered army commander. The numbered army commander will receive his operational direction from the unified commander, who will also specify the forces to be under the numbered army's operational control. The numbered army headquarters is primarily an operational echelon; however, the requirements for

its use will probably dictate that the unified command commander also delegate authority for establishing priorities for combat service support functions.

3-12. Organization

The numbered army headquarters, a TDA unit, will use the coordinating staff organization, and it will be structured to meet the specific operational requirements and circumstances for which it is formed. Its size and composition will vary according to its visualized employment, and it must include those units essential for internal functioning. Communications and control systems should receive special attention, and a command operations center capability is considered a normal requirement.

3-13. Functions

Like its organization, the scope and nature of functions the numbered army will perform will vary with the operational requirements and circumstances that necessitated its formation. Normally they will be those operational functions concerned with the tactical direction of the corps otherwise performed by the unified command as discussed in paragraphs 2-12 through 2-17, and as modified by the personalities involved and local circumstances.

DOCTRINAL RECAPITULATION

- The theater army is the army component of the unified command in a theater of operation.
- In peacetime, the theater army commander will normally retain command and operational control of all US Army forces in the theater, except Army air defense artillery elements, US Army Security Agency elements, and theater army communications command elements.
- The unified command commander will establish air defense priorities, allocate air defense resources, and appoint a single area air defense commander, normally the air force component commander, responsible for coordinating and integrating the theater air defense effort.
- In time of war, operational command of corps and other designated army combat and combat support forces required to accomplish the theater operational mission is normally assumed by the unified command commander or transferred to another headquarters the unified

command commander might designate, e.g., subordinate unified command, joint task force, or, exceptionally, a numbered army.

- In unusual wartime situations the theater army commander might be given operational responsibility for all army forces.

- Only in an emergency and on a temporary basis, or when directed by higher authority, is the theater army commander also the unified command commander.

- The theater army commander communicates directly with the Chief of Staff of the Army on uni-Service matters.

- The theater army commander exercises territorial control over the communications zone, less any land or water areas otherwise assigned.

- In peacetime, the theater army commander is responsible for overall direction and coordination of the Army intelligence effort as directed by the theater commander. During wartime, the unified command commander may require that elements of the theater army intelligence organization be placed under his operational command.

- The theater army communications command (TACCOM) is a subordinate element of the US Army Communications Command. TACCOM, under the operational control of the theater army commander, installs, maintains, and operates the theater army communications system.

- The theater army commander retains command of the theater army support command (TASCOM) and overall control of combat service support operations to insure uniformity of the support effort within the theater.

- The TASCOM provides combat service support to theater army forces and to other service components and allied forces as directed.

- The theater army is responsible for rear area protection in the communications zone.

- When unusual circumstances require a US Army echelon between corps and theater headquarters, it will have primarily a tactical function, with only directive combat service support responsibilities, and will be designated as a numbered army headquarters.

- Establishment of a numbered army headquarters will be an exception to the rule and will be tailored to the situation; hence, its size and composition will vary and will be established in tables of distribution.

- The numbered army headquarters will not normally retain terrain for which it does not further assign responsibility, and will be located to facilitate command and control, either in a corps rear area or in the communications zone.

CHAPTER 4

THE CORPS

Section I. GENERAL

4-1. Introduction

a. The corps is the Army's principal force in a theater of operations and has both tactical and administrative responsibilities. It is not a fixed organization; rather, its organization has great flexibility and will vary widely from one situation to another. Influencing factors are:

- (1) Nature and duration of assigned or visualized mission.
- (2) Characteristics of the area of operations.
- (3) Composition, characteristics, and capabilities of the enemy.
- (4) Availability of and realistic need for forces in being.
- (5) Combat service support concepts and procedures.
- (6) Support provided by other Army forces and other Services.
- (7) Available infrastructure in the theater.

In short, the corps is structured with the essential command, control, and communications system and support forces to enable the corps commander to provide operational direction to and support for the basic unit of combined arms and services fighting force—the division.

b. The corps will be assigned territorial responsibility, normally the combat zone, which entails the allocation of space to all using forces to include other Services and allies when appropriate.

4-2. Organization

b. A corps may be described by the conditions of its visualized employment.

(1) A *forward deployed corps* is one that is deployed in an established theater before the outbreak of hostilities. Additional discussion is contained in paragraphs 4-9 through 4-13.

(2) A *corps contingency force* is one that is deployed to an area where there normally is no existing US base of operations in response to a contingency for short-duration operations. Ad-

ditional discussion is contained in paragraphs 4-14 through 4-18.

b. The corps can be further characterized by the type of division forces in its structure.

(1) A *heavy corps* is one that is structured with predominantly armored and/or mechanized divisions and appropriate supporting forces.

(2) A *light corps* is one that is structured with predominantly infantry, airmobile, and/or airborne divisions and appropriate supporting forces.

c. The corps may consist of five divisions, more or less, and the essential combat support and combat service support to sustain the force. The corps commander establishes command relationships within the corps. Normally, combat and combat support units report to the corps commander and combat service support units are assigned to the corps support command (COSCOM). Units that perform both combat support and combat service support functions may be assigned to either headquarters depending on—

- (1) The primary source of mission requirements.
- (2) The physical disposition of units.
- (3) The span of control considerations.

d. Figure 4-1 provides an illustrative corps organization with subordinate elements shown by type, not size. The size of each headquarters will habitually be the smallest capable of providing the required command and control over its subordinate elements. The maximum practicable span of control for combat support and combat service support unit is emphasized.

4-3. Corps Headquarters

a. The corps headquarters and headquarters company is a TOE organization and its capabilities, limitations, reliance on other elements for support, and degree of mobility are stated in the TOE. The corps headquarters is organized

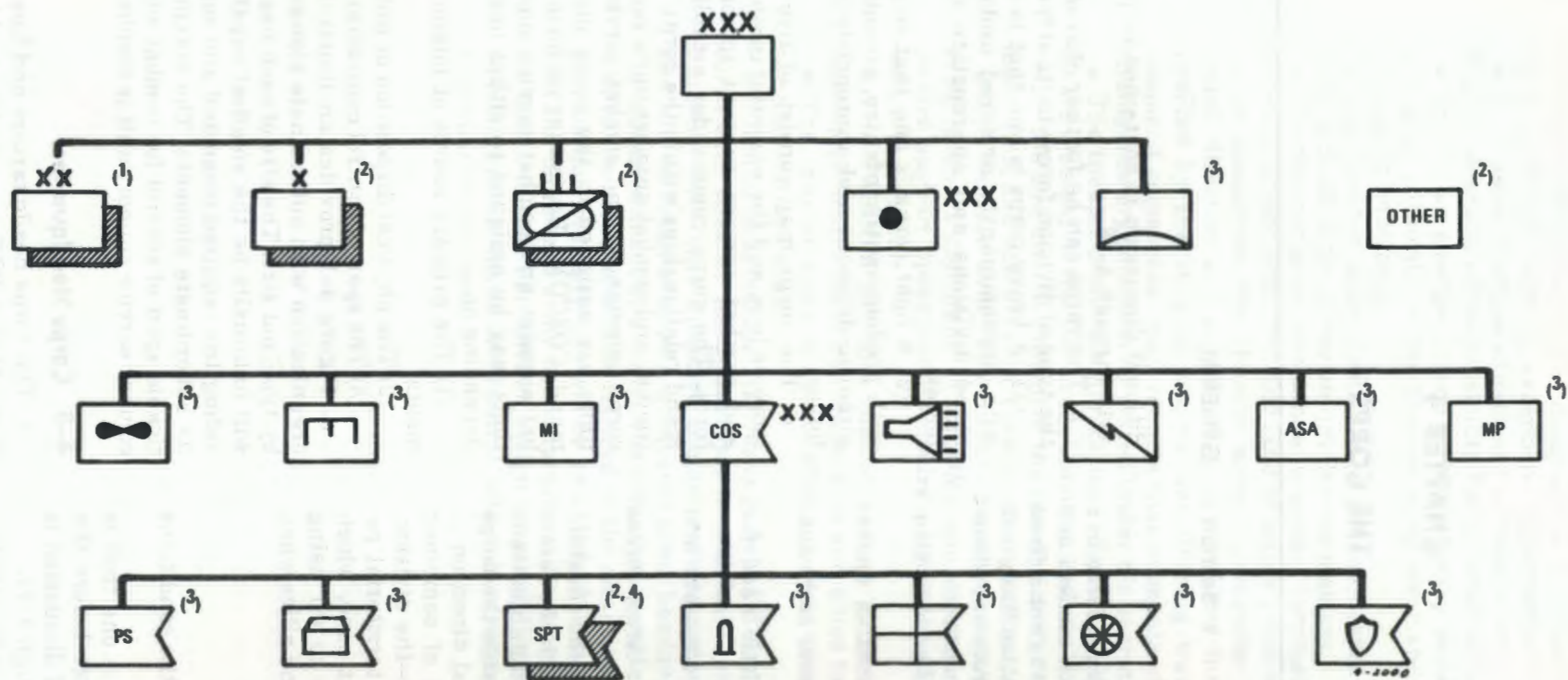

- ¹ Five divisions, more or less.
- ² Numbers and types of units will vary with requirements.
- ³ The size of the command and control headquarters will depend on the scope and magnitude of its mission to include the number of subordinate units assigned.
- ⁴ Provides DS supply and maintenance to nondivisional units and GS supply and maintenance in support of the entire corps.

NOTE: When performing combat service support missions, combat support units may be attached to either corps headquarters or COSCOM, depending on mission requirements and other considerations.

Figure 4-1. Illustrative corps in an established theater of operations.

for wartime conditions and the following factors are central to its wartime effectiveness:

- (1) 24-hour-a-day operations.
- (2) Absolute minimum-essential personnel and equipment.
- (3) Adaptability to differing battlefield environments.
- (4) Alternate and mobile tactical command post capabilities.
- (5) Peacetime TDA augmentations for performance of garrison functions.

b. The resources authorized, operational situation, and the corps commander's personality are factors that influence the location, function, and composition of the command posts.

c. The corps commander will employ some version of the tactical operations center concept—a CTOC. It functions as the nerve center for operations and planning and is normally located at the main command post (CP). The coordinating staff, their supporting personnel and equipment, and small, selected special staff sections function at the main CP. Personnel and equipment for a tactical CP may be drawn from the resources of the main CP when the corps commander desires.

d. The tactical CP provides the corps commander with a small, mobile control capability and essential staff that permit him to operate at critical places for short periods of time. When the tactical CP is employed, the CTOC continues to be the central nerve center for operations. The details of the tactical CP organization and functions will normally be standing operating procedure.

e. Some battlefield environments will require the establishment of an alternate CP to provide a reconstitution capability and a main CP displacement capability. When the TOE provides the capability to establish an alternate CP, the corps commander may collocate his alternate CP with the CP of a major subordinate combat or combat support element. When no such capability is provided by TOE and the environment requires an alternate CP, the corps commander may designate another subordinate headquarters as his alternate CP.

4-4. Command Relationships

a. In peacetime, the corps in an established theater will be under the command of the theater army commander. During wartime, however, the echelon above the corps in the operational chain of command normally will be a unified or combined headquarters.

b. Should unusual circumstances require the establishment of an army echelon above the corps, a numbered army headquarters, with tactical functions only, will be designated. Organization of the numbered army headquarters is discussed in paragraphs 3-10 through 3-13.

c. A single corps deployed in a contingency operation or conducting independent operations in an established theater will normally be part of a joint task force (JTF). Discussion concerning the corps contingency force is contained in paragraphs 4-14 through 4-18.

Section II. OPERATIONAL PLANNING

4-5. General

a. Missions assigned to the corps should be of such a nature as to permit the corps commanders wide latitude in accomplishment. Exceptionally, when operations have a strategic impact and are being used in a meticulous projection of national policy or objectives, the corps commander may receive directed missions which leave little latitude for interpretation and execution. Theater planning is discussed in paragraphs 2-7 through 2-11.

b. The corps will receive its current mission and tactical direction in an unspecified form. It may be a letter of instructions (LOI), an operation plan (OPLAN), or some other format. The basis for long-range planning by the corps will be the theater campaign plan. The LOI/OPLAN will provide some measure of detail and tactical direction necessary for the corps to execute the

first phase and prepare to execute succeeding phases of a single tactical action of the theater campaign plan. The corps commander will translate the strategic objective of the tactical action into tactical objectives and phases for accomplishment. Normally the first phase of the corps operation will be passed to the divisions for execution and succeeding phases, for planning. Divisions plan and execute the tasks specified and implied in the corps first phase. The corps will concurrently prepare long-range plans for the next theater tactical action. This planning scheme is described graphically in figure 2-4.

c. The corps commander requires adequate and timely information concerning the enemy to plan the employment of his forces. Intelligence, reconnaissance, and surveillance agencies assigned, attached, or supporting the corps

acquire information throughout the corps area of interest, while the combat units develop the enemy situation. Major subordinate commanders are kept abreast of the current enemy situation by all available means.

4-6. Command and Staff Actions

a. The corps commander analyzes the mission to identify the tasks, both specified and implied, that are essential to the successful accomplishment of the overall mission. On completion of his analysis, the corps commander provides the staff with his initial planning guidance. The corps commander's planning guidance will vary with the mission, the volume and validity of information available, the situation, the experience of his staff and the capabilities and limitations of the corps as a whole. As a minimum, the commander's initial guidance must include his restated mission. He may also include guidance concerning the employment of nuclear or chemical weapons (if appropriate), course of action considerations, the reserve, combat service support, essential elements of information, PSYOP, cover and deception, electronic warfare, or any other matters that he wishes the staff to consider during their estimates. The staff then prepare their staff estimates, which serve as a basis for their recommendations to the commander. After considering the staff recommendations, the corps commander completes his own estimate of the situation, makes his decision, and provides the staff with his overall concept of the operation. The corps commander's decision and concept of the operation provide the basis for the development of the corps operation plan (OPLAN) or operation order (OPORD). During the development and execution of OPLAN's, the commander and staff must be cognizant of the requirement for operational security (OPSEC). OPSEC involves those measures necessary to deny the enemy information concerning planned, current, and completed operations. AR 530-1 provides a detailed explanation of OPSEC measures.

b. Once execution of the plan begins and corps units are committed, radical changes in the scheme of maneuver are avoided. However, the plan/order must allow the commander sufficient flexibility so that he may take advantage of the situation during the execution. Changes in fire support normally can be made with little difficulty, but major changes affecting the planned movement of corps maneuver forces and their service support require adequate consideration of time and space factors.

4-7. Phasing a Corps Operation

a. A phase is a distinct period or subdivision of an operation, at the conclusion of which the nature and characteristics of the action usually change, and another action is initiated. A corps normally phases its operation because of the scope, duration, and complexity of the corps mission. Phasing is usually necessary when the corps commander is unable to visualize the details of an operation through to completion. It aids the commander and his subordinate commanders by segmenting an operation into manageable parts, thus facilitating planning and execution and exercising the principle of simplicity.

b. A corps usually phases its operation when—

(1) The form of maneuver or nature of the operation changes.

(2) A major regrouping of forces occurs.

(3) The commander is unable to visualize the details of the operation through to its completion.

c. The friendly and enemy situations, terrain, combat service support, time, and distance are factors that influence phasing.

4-8. Scope of the Corps Operation Plan or Order

a. The corps OPLAN/OPORD provides the concept of operation and the assignment of tasks for execution of the course of action adopted by the corps commander. It contains the details of execution for at least the first phase of the operation and outlines instructions for succeeding phases. Additional plans are developed and published as required to execute succeeding phases. The corps commander issues the detailed OPLAN for the next phase as required, or if only minor changes to the current OPORD are required, fragmentary orders may be issued to initiate the next phase of the operation.

b. The concept of operation should clarify the purpose of the operation, develop the phasing of the operation, describe the corps scheme of maneuver or form of defense and plan of fire support (which may include nuclear, chemical, naval, and air), identify the main attack or most critical sector, describe the corps formation, and identify the reserve. Electronic warfare and other matters of significance to the entire force may also be included.

c. The assignment of tasks to subordinate units will require them to execute those in the first phase of the operation and to initiate planning for one or more succeeding phases. Tasks assigned for succeeding phases are on a "prepare to" basis.

Section III. CORPS OPERATIONS IN AN ESTABLISHED THEATER

4-9. General

a. Corps operations in an established theater are characterized by nuclear-capable forward deployed forces maintained in a high state of readiness and having relatively well-established logistic facilities, firm missions, defined areas of responsibility, established command relationships, host country agreements, and planned reinforcing forces. Nuclear warfare in an established theater may be initiated at the beginning of hostilities; conversely, the conflict may remain conventional for the duration of the war.

b. Forward deployed corps will normally be part of an allied force structure that has evolved over a period of time. Initially, operations will be defensive in nature pending the arrival of reinforcing forces that will be rapidly deployed to the theater by airlift and sealift. Cover and deception will be difficult in this sophisticated environment, since intelligence activities will be intense. A disciplined force with skilled and forceful leadership will be required to cope with the defensive nature of early operations against numerically superior enemy forces.

4-10. Organization

The forward deployed corps will be structured with an economy of force based on mission, environment, and availability of forces. It will be flexibly structured to optimize its fighting capability to provide a credible in-theater deterrence and a visible sign of US presence and physical commitment. In peacetime the corps organization may be augmented with an indigenous civilian work force to economize on personnel and operating costs. Peacetime planning should make provisions for the availability of such a work force during wartime.

4-11. Command Relationships

The command relationships between the corps and next higher echelon will depend on international agreements. The peacetime command structure will normally be that of a US theater as described in chapter 2. In wartime, the corps may be part of a larger allied force and report to a combined headquarters. The latter command relationships may influence operational planning as well as training during peacetime. Command relationships within the corps are the prerogative of the corps commander.

4-12. Operational Considerations

a. *Level of Conflict.* The tactics described in succeeding sections of this chapter adequately describe corps operations in both nuclear and nonnuclear environments. The greater dispersion required for survival on the nuclear battlefield will increase command and control problems, place a premium on leadership and discipline, and require decentralization.

b. *Disposition of Forces.* Peacetime dispositions of forward deployed corps may not be ideal for wartime employment. Corps forces may be scattered throughout an area and in a locale made available by the host country. Movement to wartime deployment locations may be hampered by urbanization and civilian traffic congestion. The occupation of forward battle positions and plans to control traffic must be coordinated with host country officials.

c. *Intelligence.* The forward deployed corps will have the advantage of detailed knowledge of the potential enemy based on analyses of his doctrine, weapon systems, and leadership. Intelligence must be thorough and active to remain current on enemy capabilities, movement, and dispositions.

d. *Rear Area Protection (RAP).* The presence of the forward deployed corps in an oversea area usually will be in furtherance of a common defense effort by the United States and the host nation. To the extent that host nation civil and military forces can be relied on, their capabilities should be integrated with those of US forces in planning RAP measures and countering rear area damage and security threats.

e. *Divergent Operations.* When multiple corps are employed in the theater, operational considerations may require some forces to be widely dispersed. The nature and type of operations may also vary between corps even though directed toward the same strategic objective. Such divergent operations may alter command relationships affecting the corps commander.

4-13. Combat Service Support Considerations

a. Key to the effectiveness of combat service support (CSS) for the forward deployed forces is the rapidity with which CSS organizations can achieve a wartime footing. Like the combatant forces, CSS organizations normally will not be ideally postured to provide the logistic support and services required for combat. Divergent peacetime missions and garrison-oriented sup-

port must be phased out and geared to support in the field.

b. The transition should be preplanned and abetted by insuring that basic procedures are always in consonance with the primary combat service support mission. Thus, selective elimi-

nation of nonessential routines will not require major changes or disruptions to the logistic system. Theater war reserves, project stocks, and pre-positioned equipment will be a positive factor in achieving an initial impetus for war-time support.

Section IV. CORPS CONTINGENCY FORCE OPERATIONS

4-14. General

This section discusses corps contingency forces deployed for short-duration, limited objective, limited war conflicts in which US forces are deployed to an area where there is no existing US base of operations. Corps contingency operations are likely to be conducted in a nonactive nuclear environment and will be characterized by austerity of both personnel and equipment. The corps will operate independently and will require a rapid buildup of combat forces during the critical early stage of the conflict. This corps will have its roots in CONUS, and will rely heavily on strategic airlift for rapid deployment and resupply. Early achievement of air superiority, continuous tactical air support, and logistic resupply by air lines of communication are essential to the success of this type of operation. Such strong reliance on Air Force support suggests that a corps will habitually be employed as part of a joint task force. The task force may also require other Service component representation. Sealift of outsized equipment, armored units, and bulk supplies may be necessary. The employment of naval gunfire, tactical air support, air defense and early warning systems, electronic warfare capabilities, and marine amphibious units from naval operating forces may be critical to the success of the operation, particularly during the initial stages of deployment. In short, a corps contingency force will be a carefully structured force, operating as part of a joint task force and using economy of means and skillful execution to accomplish its objective in a short period of time.

4-15. Organization of a Corps Contingency Force

a. The corps will be carefully structured on the principles of simplicity, austerity, flexibility, and realism. It will normally be structured as a light corps. If the situation favors employment of a heavy corps, due consideration must be given to the adverse effect this will have on requirements for the rapid deployment and introduction of combat forces. The specific Army

force requirements will be determined by careful analysis of the mission, enemy, environment, estimated duration of the operation, and availability of forces. Force requirements must consider the common-, joint-, and cross-servicing agreements or assignments with other Service components of the task force. The Army component will normally be required to provide certain combat service support commodities to the forces of other Service components of the task force (fig 4-2).

b. Selective, incremental force structuring permits the achievement of austerity, not only for Army forces, but also for the entire joint task force. Within the constraints of mission-essential requirements and availability of forces, the planner must review the force structure and eliminate personnel or types of units and equipment that are not critical to mission accomplishment.

c. Successful operations require skillful execution by disciplined, well-trained units to achieve decisive results with a minimum of forces. These professional attributes and the implementation of the following procedures contribute to the achievement of truly austere forces:

- (1) Austere base development.
- (2) Minimal standards of living.
- (3) Stringent combat support and combat service support.
- (4) Reliance on strategic airlift and sealift not only for the rapid deployment of forces, but also for their continued sustainment.
- (5) Emphasis on the Air Force for close air support, tactical air reconnaissance and tactical airlift within the area of operations.

4-16. Command Relationships

a. The command relationships between the Service components and the joint headquarters are outlined in JCS Pub 2. The establishing authority of the joint force will define these relationships.

b. The corps commander will establish command relationships within the corps. These will be based on his visualized employment of the

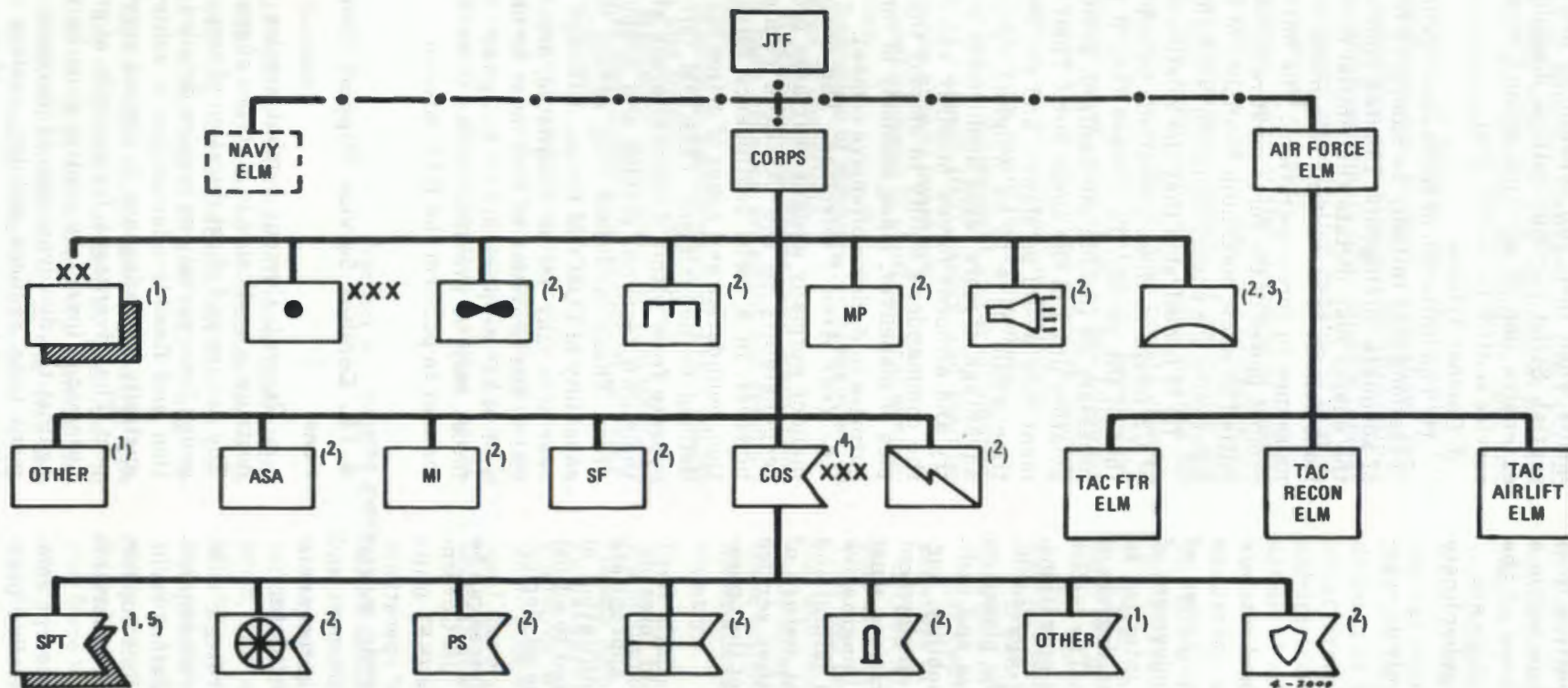

¹ Numbers and types of units will vary with requirements.

² The size of the command and control headquarters will depend on the scope and magnitude of its mission to include the number of subordinate units assigned.

³ Operational control of ADA units may be delegated to an area/regional air defense commander.

⁴ Provides DS combat service support to nondivisional units, GS to the entire corps, and such support to other Services as directed.

⁵ Composite service organization structured with supply, maintenance, and field service units.

NOTE: When performing combat service support missions, combat support units may be attached to either corps headquarters or COSCOM depending on mission requirements and other considerations.

LEGEND

— Command.

— • — Operational control.

Figure 4-2. Illustrative corps contingency force.

forces for the operation. Corps contingency force operations may require a departure from the traditional command relationships within a corps in an established theater. Some of the factors affecting command relationships are:

- (1) Physical disposition of the subordinate elements.
- (2) Span of control capabilities within echelons of command.
- (3) Mission requirements.

4-17. Operational Considerations

a. General. The limited scope and austere nature of corps contingency force operations will influence not only the organization of forces, but also the operational employment of those forces as well. This is not intended to imply changes to forms of maneuver, degrees of resistance, or the principles of war. The tactics and techniques of conducting corps operations, as described in this chapter, are applicable. However, greater emphasis must be placed on the application of certain principles and techniques; e.g., economy of force, mobility, surprise, and the bold and aggressive employment of decisive offensive actions. Operations must be characterized by flexibility, imaginative leadership, intuitive planning, and skillful and decentralized execution. The joint nature of these operations dictates that other service support will enter into all aspects of the operations.

b. Introduction of Forces.

(1) Contingency plans for rapid force deployment currently exist at the appropriate levels of command; however, modification of these plans will normally be required to adjust to existing conditions at the time of deployment.

(2) The introduction of combat forces can be facilitated by effectively utilizing US Government agencies and special forces (SF) units that may be present in the area of operations. These agencies and units can establish initial liaison with the host country government and armed forces and contribute to early reconnaissance and estimates of existing conditions.

c. Communications.

(1) Early establishment of strategic communications is essential to mission accomplishment. Mobile packaged communication facilities, such as the Joint Communications Support Element (JCSE), should be considered for this type of contingency operation.

(2) The technical nature of the corps communications systems demands detailed planning. Austerity of communications personnel and equipment within the corps can be

achieved by selective tailoring of signal elements when their full capabilities are not essential. Strict communications discipline and extensive use of air and ground messenger service contribute to this goal.

d. Combat Actions.

(1) The initiation of corps contingency force operations may initially be hampered by a lack of adequate intelligence. Limited knowledge of the enemy may dictate that initial combat actions consist of movement to contact or reconnaissance in force operations. The bulk of the combat power of the force must remain uncommitted to allow maximum flexibility of employment once the enemy situation is developed.

(2) It is desirable that the relative mobility of US forces in these operations be superior to that of the enemy. To achieve this, it may be necessary to include mechanized, armored, or aviation units in the corps force. Their deployment rate would be slower, and the impact of time would have to be weighed against the advantage of more rapid deployment by infantry and airborne forces. Mobility will enhance the commander's ability to employ the principles of maneuver, mass, economy of force, and surprise in decisive offensive combat.

e. Rear Area Protection. The corps commander normally assigns rear area protection responsibility to the COSCOM commander; however, in a corps contingency force operation, boundaries and zones of action may be ill-defined or nonexistent. COSCOM forces may operate from within divisional areas and from their own terminal service and support base areas. These conditions may reduce the RAP capability of COSCOM forces. Although a corps rear area may not be designated, areas essential to the provision of CSS must be identified and RAP responsibility assigned. Combat forces may be provided to the COSCOM commander to perform the RAP mission.

4-18. Combat Service Support Considerations

a. General. Current combat service support doctrine is applicable to all types of operations. The nature and short duration of corps contingency force operations require detailed evaluation and flexible adaptations to achieve both austerity and adequacy in combat service support. The advantages, for example, of providing automated inventory control must be weighed against the disadvantages of increased deployment time, reduced mobility, system vulnerability, and lengthy setup time. If the state of the art allows remote terminals within the area

of operations to the computers in CONUS, combat service support, managed in the CONUS, may be more effective and economical by taking advantage of these communications and computer systems.

The principles of flexible unit structuring, direct support/general support, centralized control/decentralized operations, and throughput distribution all contribute to an austere combat service support organization capable of providing the required support.

b. Logistics. Each of the elements of logistic support requires careful analysis to determine the most economical means of providing the support. The setup time and requirements for personnel and equipment may negate providing the service support in-theater. Evaluation and application of some or all of the following concepts will aid in providing effective support with a minimum investment in resources.

(1) Maximum use of local resources.

(2) Selective curtailment and/or elimination of general support (GS) supply and maintenance in the area of operations.

(3) Establishment of short medical evacuation policy.

(4) Reduction of stockage levels maintained in the area of operations.

(5) Reduction of order and ship time through high reliance on airlift for resupply operations.

(6) Maximum employment of direct supply support and throughput concepts.

(7) Maximum utilization of containerized shipments and, conversely, reduction in break-bulk operations.

c. Personnel and Administrative Services. Centralized personnel and administrative activities responsive to the corps is a desirable goal. However, short-duration combat opera-

tions, tend to favor leaving computer systems in CONUS with consequent decentralized administration within the area of operations. Divisions in CONUS are normally stationed at considerable distances from each other; movement of the divisions' computer systems to a central location in the CONUS or to the theater may not be practical for the short term. Such a decision is complicated by the fact that computer systems of the division are shared by administrative and logistic activities. Centralization of administrative activities for nondivisional units may provide a desirable alternative.

The following concepts can simplify administration and reduce force requirements in the area of operations. Their implementation must consider the duration of the operation.

(1) In-theater maintenance of only emergency data and a minimum of records.

(2) Centralized finance and comptrollership activities in CONUS.

(3) Centralized personnel administration activities in CONUS.

d. Civil Affairs. Civil affairs activities in support of short-term operations will be minimal. They will be primarily concerned with identifying and isolating potential problems that directly affect combat operations. The extent of these activities will be dependent on US policy, international law, or agreements with the host country.

Civil affairs units will be predominantly command support, structured with only those specialists identified as essential. In unusual circumstances, area support units may be employed when major population centers are uncovered and it is essential to reestablish the local government apparatus and facilities in order to effectively support military operations.

Section V. CORPS OFFENSIVE OPERATIONS

4-19. General

a. This section discusses offensive operations and should be considered in conjunction with the operational considerations outlined in paragraphs 4-9 through 4-18 and 4-43 through 4-46.

b. Offensive operations seek to destroy the enemy and are characterized by retention of the initiative, thus permitting the commander to impose his will on the enemy at the time and place of his choosing. Whereas offensive operations are traditionally associated with a favorable combat power ratio and a deteriorating

enemy situation, these are not necessarily preconditions for offensive action. Mobility, surprise, and aggressive execution are the most effective means to success in the offense. Increased risk may be involved with bold, hard-hitting tactics; however, greater gains normally require greater risks. The initiative may be gained and retained by a numerically inferior force that is capable of bold and aggressive action. Accordingly, a numerical superiority is not necessarily a precondition for offensive operations; rather, commanders must continuously seek every opportunity to seize the initia-

tive through offensive action even when the force as a whole is on the defensive.

4-20. Missions

The corps commander's mission and concept of operation serve as the basis for the assignment of tasks to divisions and other subordinate commands. Tasks assigned to the divisions are normally more specific than the mission assigned to the corps and usually require the divisions to secure specific terrain, destroy enemy forces, or both.

4-21. Coordination and Control

Effective and efficient application of combat power requires full coordination of effort to insure that maximum advantage is derived from forces available. The corps prescribes only the necessary coordination and control measures to insure unity of effort. These measures may include, as appropriate:

- a. Lines of departure.
- b. Time or times of attack.
- c. Zones of action.
- d. Axes of advance.
- e. Phase lines.
- f. Objective areas.
- g. Boundaries.
- h. Link-up points.
- i. Fire support coordination line (FSCL).
- j. Fire coordination line (FCL).
- k. Limit of advance.

4-22. Offensive Forms of Maneuver

a. *General.* The corps employs one or a combination of the basic forms of maneuver—the penetration, envelopment, or the frontal attack. The selection of a form of maneuver is based on an analysis of the mission; terrain; available time; disposition and capability of available forces; ability to support the operation; and the disposition, composition, and strength of the enemy force. The divisions are the tactical units of execution, and a corps offensive operation is actually a series of coordinated and integrated division operations. The distinction in the form of maneuver adopted by corps exists primarily in the intent of the corps commander, since the subordinate elements may use other forms of maneuver.

b. *Penetration.* Corps employs this form of maneuver when the enemy dispositions, characteristics of the terrain, or the inherent limitations of the attacking forces preclude the adoption of a scheme of maneuver which avoids the principal defenses of the enemy.

- (1) The penetration attacks the principal

defensive positions to rupture and destroy the continuity of the enemy defense, divide his forces, and defeat them in detail (fig 4-3). The penetration is appropriate when strong fire support and adequate maneuver forces provide a favorable combat power ratio or when the enemy is overextended and his flanks are unsailable.

- (2) The penetration will normally employ a main and a holding (supporting) attack. The holding attack should have sufficient combat power to deceive the enemy as to the location and intent of the main attack; to fix the enemy in his present positions, thus reducing his freedom of action to react against the main attack; and to cause the enemy to delay in committing his reserve or to commit his reserve prematurely and indecisively. The main attack breaches the initial defensive positions; widens the gap and destroys the forces in the area of the penetration; then exploits success in the area of the penetration to secure vital objectives in the enemy rear area.

- (3) Priority of fire support is employed to assist the main attack to break the initial defenses, while adequate fire support is provided to the holding attack. After the penetration has been made, the reserve may be passed through for exploitation and pursuit.

c. *Envelopment.* This form of maneuver is adopted when the enemy dispositions, nature of the terrain, and inherent capabilities of the attacking force afford the opportunity of adopting a scheme of maneuver that avoids the principal enemy defenses (fig 4-4).

- (1) A holding attack strikes the principal enemy defenses to deceive the enemy as to the location and intent of the main attack; fix the enemy in his present positions; prevent his escape; reduce his capability of reacting against the main attack; and cause the enemy to commit his reserve prematurely or indecisively.

- (2) The main attack is the enveloping force that passes around or over the enemy's principal defenses to secure deep objectives that cut his escape routes, force him to fight in two or more directions simultaneously, and subject him to destruction in position.

- (3) Equal or superior mobility, surprise, and avoidance of the enemy's principal defenses by the main attack are essential to the success of an envelopment. Enemy resistance that would interfere with rapid movement may be bypassed and reduced by supporting fires or other forces. Security forces protect the enveloping force's exposed flanks. Vertical envelopments may be conducted to secure deep objec-

tives. When the situation permits, the envelopment is generally preferred to the penetration because it offers a greater opportunity for exploitation and avoids the enemy's main positions.

(4) The double envelopment is a variation of the envelopment. A holding attack or fixing force may be employed while both flanks of the

enemy are bypassed to secure deep objectives from two directions. Detailed planning and execution, as well as superior mobility and combat power, are paramount to success. This maneuver involves a greater degree of risk; but, it affords the attacker an opportunity to trap and destroy the hostile force.

(5) The turning movement is still another

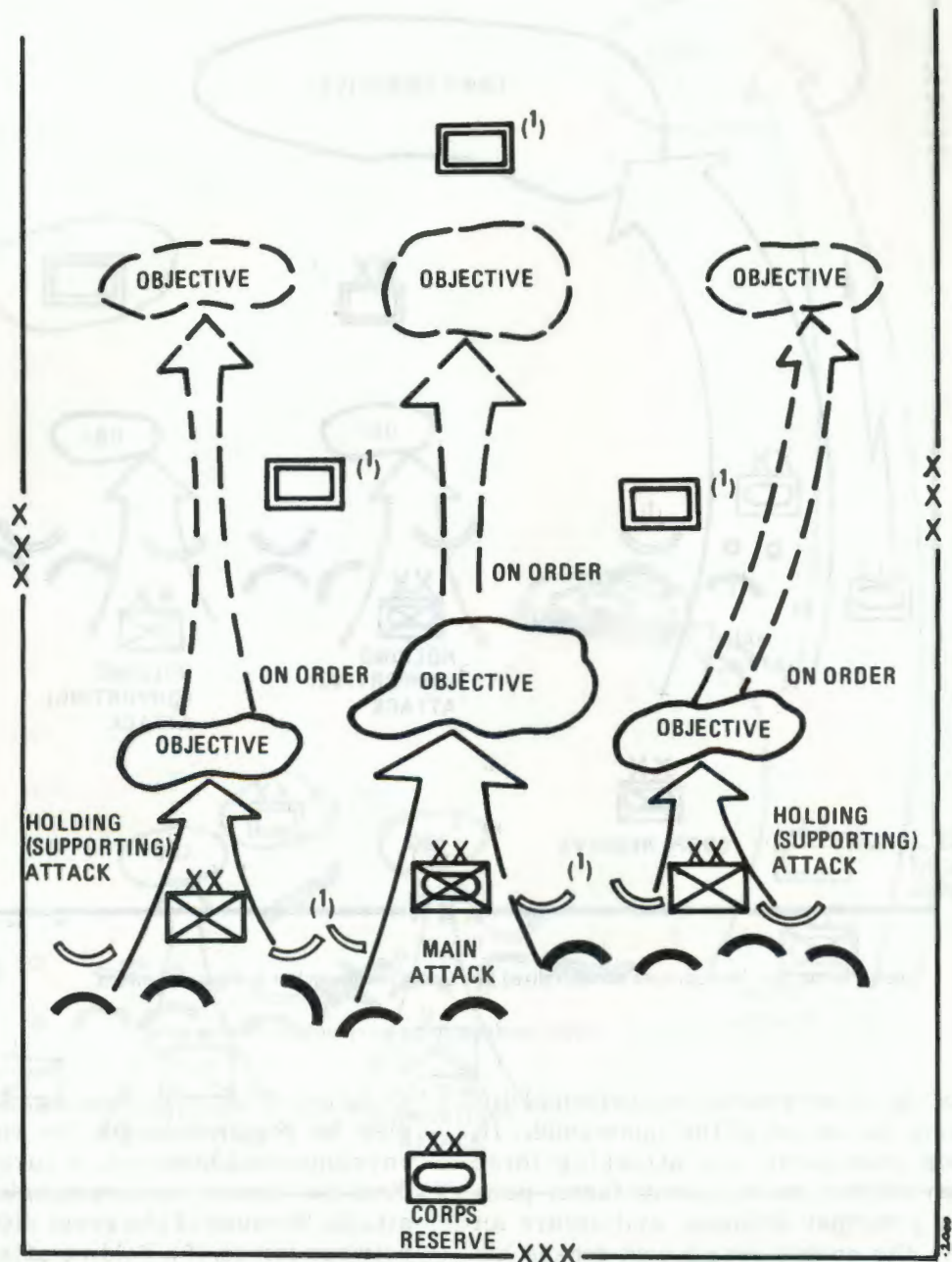

¹Enemy forces may be destroyed or neutralized by nuclear or nonnuclear fire support means.

Figure 4-3. Corps conducting a penetration (schematic).

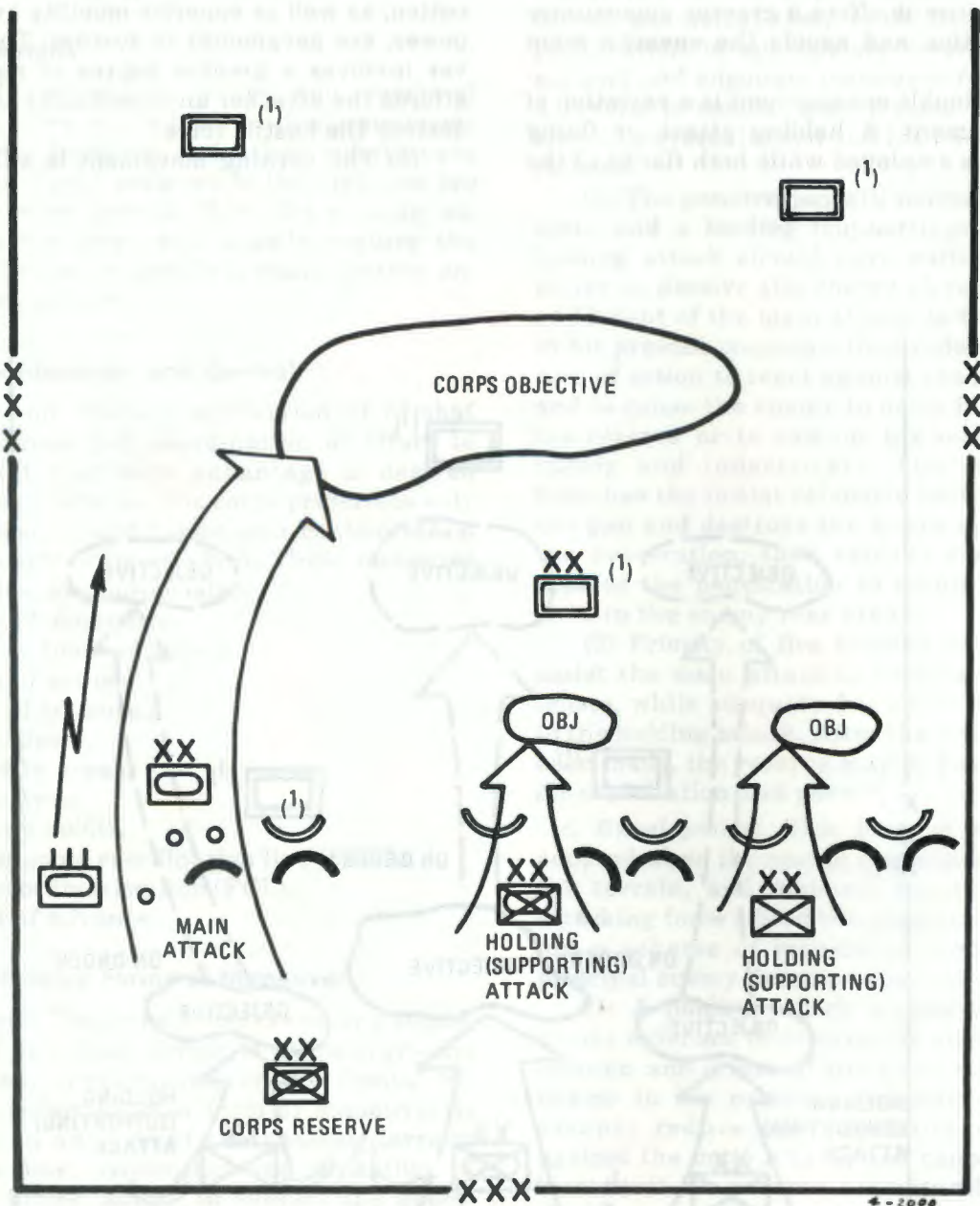

¹ Enemy forces may be destroyed or neutralized by nuclear or nonnuclear fire support means.

Figure 4-4. Corps conducting an envelopment (schematic).

variation of the envelopment—the principal difference being the intent of the commander. In the turning movement, the attacking force seeks to avoid the main enemy force, pass around the principal defenses, and secure an objective in the enemy rear which makes his present position untenable (fig 4-5). The purpose of this maneuver is to force the enemy to divert major forces to meet the threat or to abandon his position altogether, thereby enabling the attacker to engage the enemy in a

situation of his own choosing. A holding attack may be required to fix the enemy, as in an envelopment; however, a turning movement need not always be accompanied by a holding attack. Because of the great distances involved between forces, if a holding attack is employed, each force must be sufficiently strong and mobile to operate independently.

d. Frontal Attack. The purpose of the frontal attack is to overrun and destroy or capture the enemy in his present positions or to fix him in

position. It may be employed as the fixing force in an envelopment. It may be conducted in order to develop the situation; e.g., to determine the enemy's strengths and weaknesses or his intent. The frontal attack can be decisive when conducted against an overextended or disorganized enemy, or when the attacker has overwhelming combat superiority.

e. Execution. The corps commander normally

does not specify the form of maneuver to be adopted by the division. However, the assignment of tasks, zones of action, and the allocation of combat power may impose such limitations on the division that there is little choice of the form of maneuver.

4-23. Advance (Movement) to Contact

a. Corps conducts an advance to contact in order to establish or regain contact with the

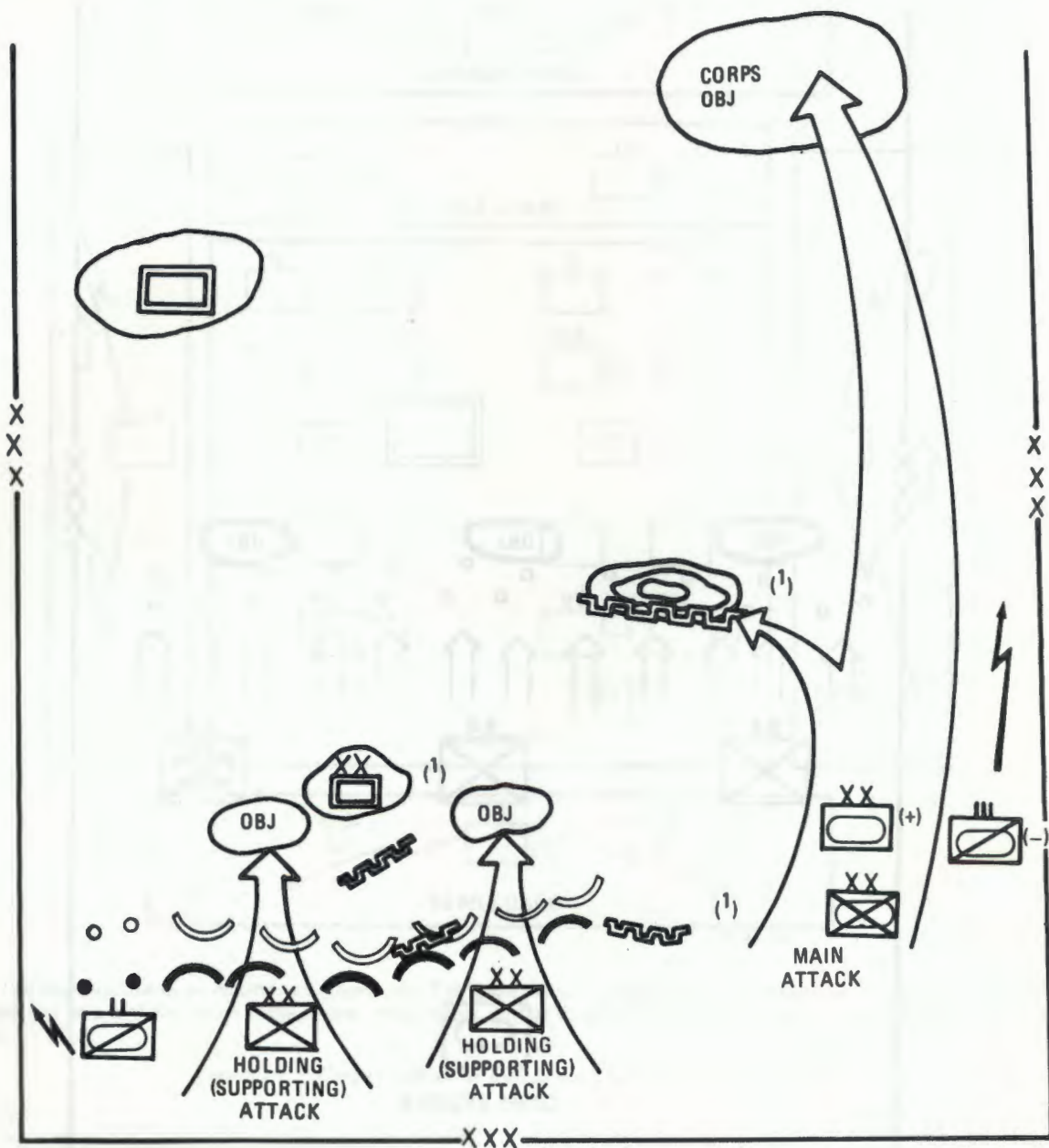

¹Enemy forces may be destroyed or neutralized by nuclear or nonnuclear fire support means.

Figure 4-5. Corps conducting a turning movement (schematic).

enemy. The operation is characterized by centralized planning by the corps and decentralized and aggressive execution.

b. The corps is organized with a covering force, a main body, and advance, flank, and rear guards (fig 4-7). The size and composition of the covering force will vary depending on the

nature of the terrain, the enemy threat, width of the corps zone, the nuclear situation, and forces available. The purpose of the covering force is to provide for the uninterrupted forward movement of the main body, protect the main body from surprise, locate the major enemy forces, and develop the enemy situation.

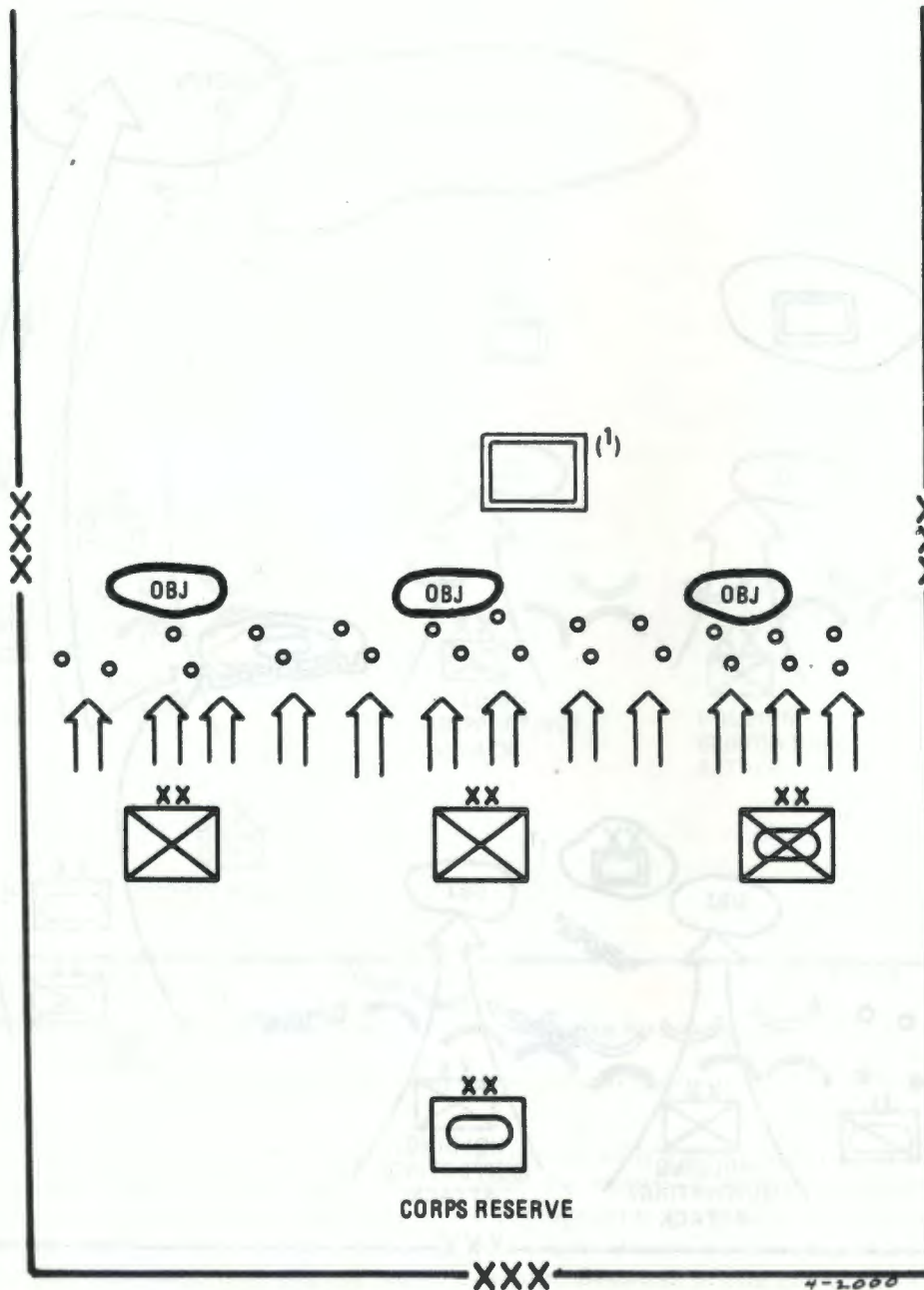

¹Enemy forces may be destroyed or neutralized by nuclear or nonnuclear fire support means.

Figure 4-8. Corps conducting a frontal attack (schematic).

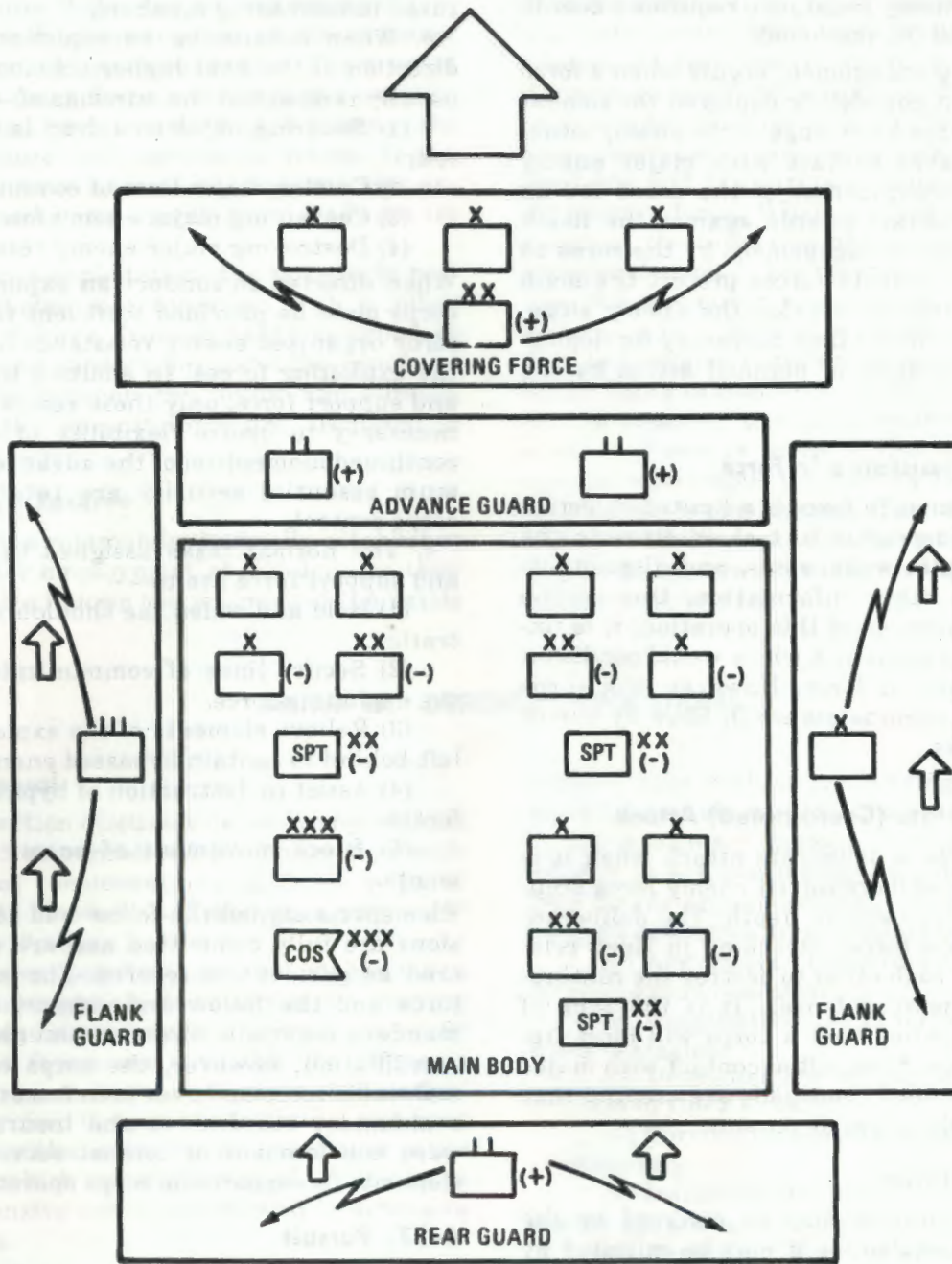

NOTE: This figure represents an illustrative example only. The actual size and composition of the covering force, advance, flank, and rear guards will vary with the nature of the terrain, enemy threat, nuclear situation, size of the corps zone, forces available, and other variables.

Figure 4-7. Corps conducting an advance to contact (schematic).

The covering force commander operates under the control of the corps commander. Flank and rear guards protect the main body from ground observation and surprise attack and may operate under corps control or under the control of their parent unit. The bulk of the corps forces

constitutes the main body. Divisions in the main body are organized for combat, moving in tactical formations. An advance guard, provided by the main body, maintains contact with the covering force, provides security to the front, and expedites movement of the main

body. The advance to contact terminates when determined enemy resistance requires a coordinated effort of the main body.

c. A meeting engagement occurs when a force is moving, not completely deployed for combat and with limited knowledge of the enemy situation, and makes contact with major enemy forces. The organization of the corps for an advance to contact guards against the likelihood of a meeting engagement by the corps as a whole. The security forces protect the main body from surprise, develop the enemy situation, and provide the time necessary for deployment and execution of planned action by the main body.

4-24. Reconnaissance in Force

A reconnaissance in force is a limited-objective attack. Its purpose is to test or discover the enemy strength, weaknesses, and dispositions or to obtain other information. Due to the nature and purpose of this operation, it is unlikely that the corps as a whole would conduct a reconnaissance in force. However, the corps may order a reconnaissance in force by one or more divisions.

4-25. Deliberate (Coordinated) Attack

Corps conducts a deliberate attack when it is opposed by a well-organized enemy force occupying defensive belts in depth. The deliberate attack employs forces attacking in fixed relationship with each other to destroy the continuity of the enemy defenses. It is the type of offensive operation that a corps will most frequently conduct from initial contact with major enemy forces until conditions are created that favor the exploitation or pursuit.

4-26. Exploitation

a. An exploitation may be directed by the next higher echelon, or it may be initiated by the corps commander to exploit successes. The exploitation is designed to destroy the enemy's ability to reconstitute an organized defense or to conduct an orderly withdrawal in the face of threatened destruction or capture. The opportunity to conduct an exploitation usually is indicated when—

- (1) The enemy's command and control has been seriously degraded.
- (2) The enemy is having difficulty maintaining his position.
- (3) Friendly forces are making decisive gains.
- (4) Enemy resistance, particularly supporting fires, is lessening.

(5) Prisoners and equipment are being captured in increasing numbers.

b. When conducting an exploitation at the direction of the next higher echelon, the corps usually is assigned the missions of—

- (1) Securing objectives deep in the enemy rear.
- (2) Cutting major lines of communication.
- (3) Containing major enemy forces.
- (4) Destroying major enemy reserves.

When directed to conduct an exploitation, the corps must be provided sufficient forces to destroy organized enemy resistance bypassed by the exploiting forces. In addition to the follow and support force, only those reserves that are necessary to insure flexibility of operations, continued momentum of the advance, and minimum essential security are retained under corps control.

c. The normal tasks assigned to the follow and support force are to—

- (1) Hold and widen the shoulders of a penetration.
- (2) Secure lines of communication behind the exploiting force.
- (3) Relieve elements of the exploiting force left behind to contain bypassed enemy.
- (4) Assist in destruction of bypassed enemy forces.
- (5) Block movement of enemy reinforcements.

Elements assigned the follow and support missions are fully committed and are not considered as part of the reserve. The exploitation force and the follow and support force commanders maintain direct communication and coordination; however, the corps commander maintains command over both forces. The corps commander coordinates and insures the forward echelonment of combat service support elements to support the corps operation.

4-27. Pursuit

a. The purpose of the pursuit is to destroy a hostile force attempting to escape. As the continuity of enemy forces begins to disintegrate under relentless pressure, an exploitation may develop into a pursuit. A pursuit may also occur when the enemy attempts to disengage and retire. Although terrain objectives may be designated, the destruction of the enemy force is the primary objective of the corps. During the pursuit, corps advances on a broad front with maximum combat power forward, maintaining only that reserve which is necessary to provide flexibility of action and continued momentum.

b. The pursuit usually consists of direct pres-

sure and enveloping forces. The mission of the direct pressure force is to prevent enemy disengagement and reconstitution of his defenses and to inflict maximum casualties. The mission of the enveloping force is to block the enemy's escape so that he can be destroyed between the direct pressure and enveloping forces. If the enveloping force cannot outdistance the enemy, it attacks the enemy main body on its flanks.

c. As in the exploitation, the pursuit is normally conducted in conjunction with a follow and support force. Normal tasks assigned to the follow and support force and the command relationship between the follow and support force and the pursuit force are discussed in paragraph 4-26.

4-28. Corps Reserve

a. The corps commander normally establishes a reserve for employment at the decisive time and place. He follows the progress of the battle

and adjusts or modifies missions assigned to the subordinate units, to include relief of forces that have become exhausted or attrited during combat. At the decisive moment, he commits the reserve to exploit success and immediately reconstitutes another reserve. The size of the corps reserve will vary depending on the forces available and the strength and disposition of the enemy force. When nuclear weapons are assigned, the corps commander considers them a major element of his reserve.

b. The maneuver elements of the corps reserve may be a division, a separate brigade, an armored cavalry regiment, or a combination of these. Unity of command of the reserve is critical. On occasion, the corps reserve may be the reserve of one or more of the divisions, with specific restrictions imposed by the corps commander on its employment. The reserve is positioned to facilitate its anticipated employment. The corps reserve is usually committed directly under corps control.

Section VI. DEFENSIVE OPERATIONS

4-29. General

a. This section discusses defensive operations and should be considered in conjunction with the general considerations outlined in paragraphs 2-12 through 2-17 and paragraphs 4-9 through 4-18 above.

b. Defensive operations are undertaken when national interests are best served by limiting thrusts deep into enemy-held territory or when insufficient forces are available for offensive action. In any event, the principle of the offensive is exercised to seize the initiative and keep the enemy off balance. The counterattack is the means by which the fundamental of maximum use of offensive action is achieved in defensive operations.

4-30. Defensive Echelons

Defensive echelons include the security echelon, the forward defense echelon, and the reserve echelon. Each echelon is allocated forces and fires in accordance with the corps defensive plan.

a. Security Echelon.

(1) The security echelon occupies the area forward of the FEBA and establishes contact with the enemy forward of main defensive positions. It is used to deceive, delay, disorganize, and canalize the enemy. These forces, therefore, should be highly mobile and representative of the force as a whole. The corps security

echelon may include a covering force, flank security, and air surveillance units.

(2) A primary mission of a corps covering force is to achieve maximum delay to provide time for the organization and occupation of the forward defensive area. Time is gained by—

(a) Aggressive offensive action and skillful retrograde operations.

(b) Imaginative use of natural and man-made obstacles.

(c) Deceiving the enemy as to the true location of the FEBA.

(d) Forcing the enemy to deploy his force prematurely.

(e) Inflicting maximum casualties as the enemy advances.

(f) Providing early warning of enemy movement.

(3) The corps commander may also direct the establishment of a general outpost (GOP)—the division commander's security echelon. Based on the recommendations of the divisions, the corps commander establishes the general trace of the GOP by designating the coordinating points within the corps sector. The corps commander will normally prescribe the time that the GOP is to delay the enemy forward of the FEBA.

b. Forward Defense Echelon.

(1) The corps forward defense area (FDA) is that area extending from the FEBA rearward to include the area occupied by the reserve of

the FDA divisions. The corps commander organizes the corps FDA by designating coordinating points along the FEBA and establishing lateral and rear boundaries that delineate division defensive sectors. Normally, corps employs division-sized forces in the FDA, but limitations on available forces or extended frontages may require the employment of separate brigades or armored cavalry regiments in FDA economy of force roles.

(2) Division sectors are assigned based on the capability of the division, the terrain within the sector, and the mission assigned the division. Usually, the assigned sector is astride a major avenue of approach. A major avenue of approach from the corps viewpoint is one that will permit the unrestricted maneuver of at least one deployed enemy division.

(3) Blocking positions may be designated by the corps to add depth to the defense and to slow, canalize, or contain enemy penetrations. They are located to protect key terrain and support counterattack plans. Corps engineers, reserve units, and other corps troops may be tasked to construct corps blocking positions as time and materiel permit.

c. Reserve Echelon. The reserve echelon, composed of uncommitted forces under corps control, occupies positions as directed and adds depth to the defense. It will normally be positioned in the corps rear area, but occasionally may occupy portions of division rear areas. The discussion in paragraph 4-28 relative to the composition of the reserve in offensive operations also applies to defensive operations.

4-31. Forms of Defense

There are two forms of defense—mobile and position. They rest at opposite ends of a spectrum with little likelihood of either being precisely adaptable to a battlefield situation. Rather, it is most likely that a defensive posture ranging somewhere between the mobile and position will be required. The form of defense adopted by the corps depends on the intent of the corps commander and will be determined by the mission, forces available, the nature of the terrain, relative combat power to include mobility, the nuclear situation, and the air situation. Operations of the corps' subordinate elements may encompass combinations and variations of both forms of defense. In the mobile defense, the intent is to employ a relatively large corps reserve in decisive action to destroy enemy forces. In the position defense, the intent is to employ forces well forward in the FDA to retain terrain and to counterattack when forced to do so by enemy gains.

a. Mobile Defense.

(1) The corps mission will normally permit the defense to be organized and fought in great depth. Adoption of this form of defense, however, requires that the corps have mobility at least comparable to that of the enemy; local friendly air superiority is highly desirable. The mobility of the mechanized and armored divisions and the capability to mechanize, airlift, or motorize infantry divisions are considerations for adopting the mobile defense. The dispersion and mobility required to decrease the vulnerability when nuclear weapons are employed favor the mobile defense with the counterattack being conducted by small, highly mobile forces and nuclear weapons. The employment of nuclear weapons permits the defense of wider frontages than would otherwise be possible.

(2) In the conduct of a defense, the corps employs security forces forward to warn of impending attack, to canalize the enemy into less favorable terrain, and to harass, impede, deceive, and disorganize the enemy. In the mobile defense, at least one maneuver unit of the corps in the forward defensive area is given the mission of delaying the enemy into an area favorable for the counterattack. There he is engaged by decisive offensive action. A large mobile reserve is used to counterattack and destroy the enemy force contained in the penetration (fig 4-8). A successful counterattack may lead to the resumption of offensive operations by capitalizing on the destruction of the enemy force and regaining of the initiative.

(3) The corps achieves the increased depth required in a mobile defense by—

(a) Locating combat and combat support units in depth.

(b) Locating combat service support units farther to the rear.

(c) Requiring divisions to prepare blocking positions in depth.

(d) Designating and constructing blocking positions located in division rear areas. These normally are occupied only on corps order.

b. Position Defense.

(1) Assignment of a mission that requires the corps to retain specific terrain may dictate the adoption of a position defense. A position defense also may be indicated by—

(a) Terrain that restricts the movement of the corps reserve.

(b) Superior tactical mobility of the enemy.

(c) Local air superiority by the enemy.

(2) In the position defense, the corps places the bulk of its combat forces in the forward

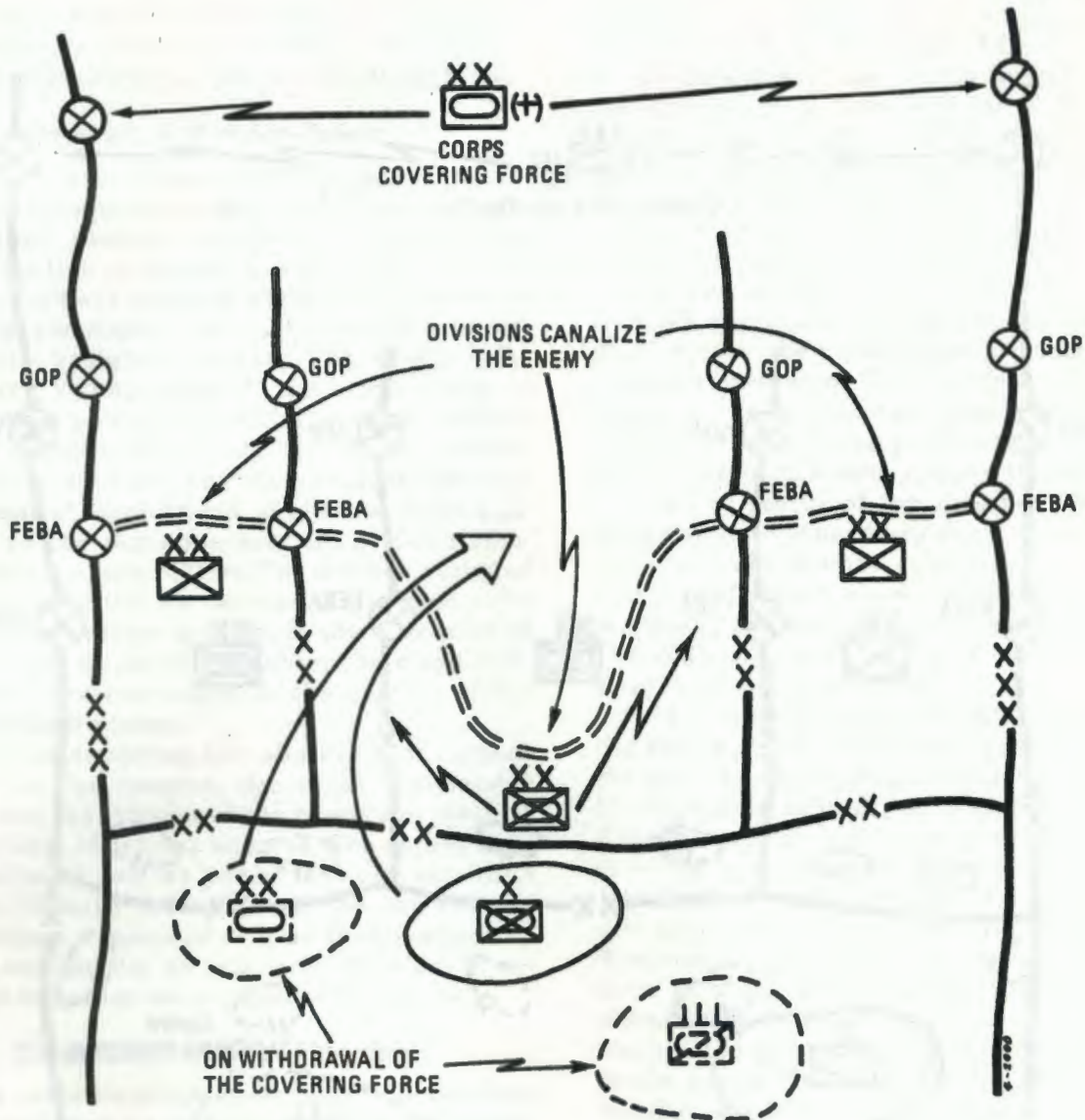

Figure 4-8. Corps conducting a mobile defense (schematic).

defense area, withholding a small reserve. The reserve will be employed to execute counterattack plans, reinforce forward units, or execute blocking missions. The primary mission of the counterattack in the position defense is to regain control over the forward defense area, since retention of specific terrain was the original intent (fig 4-9). Terrain permitting, the corps reserve is usually positioned farther forward than in the mobile defense. The reserve may be disposed laterally to facilitate its intended employment.

4-32. Defensive Planning

a. Mission Analysis and Planning Guidance. In his mission analysis, the corps commander identifies specified and implied tasks that are essential to the accomplishment of the mission.

Once mission analysis is completed, the corps commander will normally restate his mission and issue his planning guidance to the staff. Such guidance may include the form of defense to be adopted by the corps and sufficient other information to guide the staff in their estimates.

b. Defensive Operation Estimate. After a detailed analysis of the weather and terrain, friendly and enemy situations, relative combat power, and probable enemy courses of action, the corps G3 will develop feasible defensive courses of action. Formulation of a corps defensive course of action may take the following sequence:

(1) Determine the mission (defend or delay) on each major avenue of approach into the corps sector.

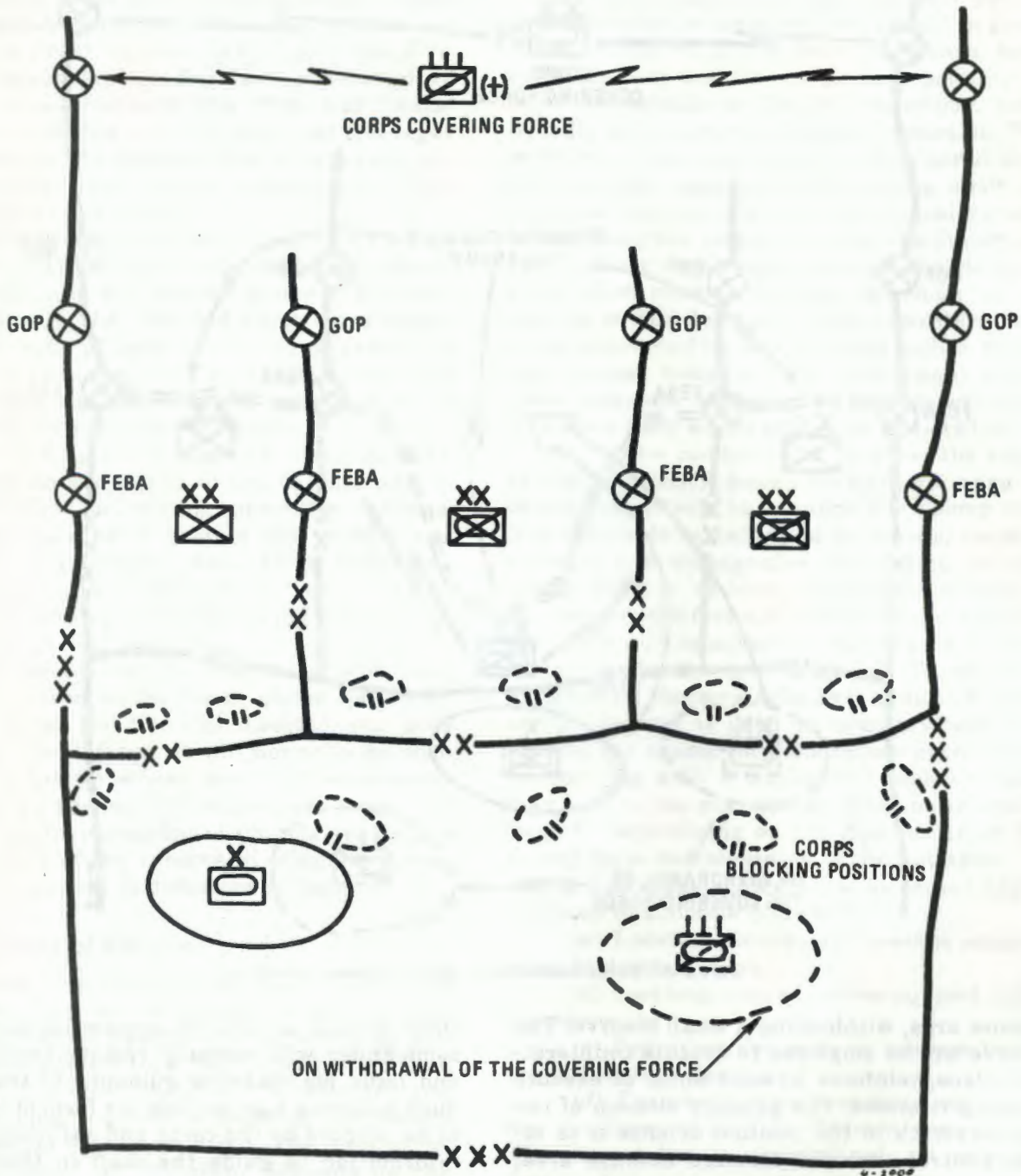

Figure 4-9. Corps conducting a position defense (schematic).

- (2) Assign sectors to major subordinate elements.
- (3) Allocate available combat power to all echelons.
- (4) Adjust as necessary.

4-33. Missions to Units in the Forward Defense Area

The corps does not normally prescribe the form of defense for use by the division or other

subordinate units in the FDA. Divisions are assigned sectors, and the execution of the defense is left to the division commanders. The size of the sector assigned to the division, the terrain, the type of combat forces allocated to or placed in support of the division, the air situation, the time available for organizing the defense, and the capabilities of the enemy forces largely determine the form of defense adopted by the division commander. In the corps mobile defense, at least one division is

assigned a mission of delaying the enemy and, thereafter, to contain the enemy in the planned area of penetration as part of the fixing force.

4-34. Allocation of Combat Power

a. The corps allocates combat power to the forward defense and reserve echelons to accomplish their assigned missions. In determining the allocation of combat power to the divisions in the forward defense area, the corps commander visualizes how each division can defend its assigned sector. The corps commander's visualization of the employment of the combat power is essential to the soundness of the planned allocation. The actual disposition of the divisions and their attachments and the planned employment of other support allocated to the divisions are the division commander's responsibilities. The division assigned the responsibility for defense of the most critical sector receives priority in the allocation of combat power. In this manner, the corps commander provides weight to the defense of the most critical sector.

b. In determining the allocation of combat power to the reserve, the corps commander considers the mission of the reserve in relation to the form of defense adopted. The appropriate allocation of combat power between the units in the forward defense area and the reserve establishes a balanced defense that enables the corps commander to retain the freedom of action to influence the conduct of the battle.

4-35. Corps Counterattack Planning

a. A corps counterattack is an offensive action conducted by the corps reserve. The counterattack plan is developed by the corps staff to support the adopted form of defense. All subordinate units assigned missions in the corps counterattack plan develop detailed implementing plans.

b. Depending on the situation and time available, the corps may develop counterattack plans for a visualized penetration on each major enemy avenue of approach into the corps sector. Each counterattack plan is based on a particular set of assumptions. These assumptions include—

(1) The size and location of the penetration. The width of the assumed penetration is determined primarily by the terrain and enemy doctrine. The depth of the penetration is determined by terrain, the corps' defense plans, and the size of the enemy force assumed to be within the penetration. This assumed penetration is the maximum allowable penetration. It reflects the visualized configuration of the pen-

etration at the time the counterattack force crosses the line of departure (LD).

(2) The size of the enemy force within the penetration. This force will be of a size that exceeds the capabilities of the divisions in the forward defense area to destroy or eject from the penetration. However, the size of the force assumed to be in the penetration must be within the corps' capability to destroy or eject.

(3) The ability to stop or slow the penetration. An assumption relating to the corps' ability to control the penetration is essential to the counterattack plan. The counterattack plan is based on an assumption that the corps has stopped or slowed the penetration at the time the counterattack force crosses the LD.

(4) The status of the reserve. The plan is predicated on the maneuver reserve being available and combat effective. This assumption is particularly necessary when the reserve is initially committed as a corps covering force. The plan may also be based on assumed nuclear weapon assignments.

(5) The air situation. An assumption about the status of the local air situation at the time the plan is ordered into execution is necessary. In the mobile defense, the ability to maneuver a large reserve without unacceptable losses is essential to the success of the counterattack.

c. Nuclear weapons from the corps reserve are allocated for each counterattack plan. Weapons are allocated to the counterattacking force to blunt the offensive by disrupting the momentum and continuity of the attack, to contain the penetration, and to destroy enemy forces inside the penetration. Weapons allocated to the fixing forces assist in controlling the penetration and prevent or contain secondary penetrations. Corps also will plan additional weapons to seal the penetration and destroy enemy reinforcements and reserves.

4-36. Conduct of the Counterattack

a. The corps commander counterattacks when the enemy attack slows, stops, or becomes disorganized, preferably before the enemy can consolidate his gains and reorganize or regroup his forces.

b. The determination of the proper time to order execution of the counterattack plan is considerably more difficult at corps than at division, primarily because of the time and space factors involved in moving the counterattacking force from its reserve location to the LD. The corps commander and his staff continuously evaluate the tactical situation against the assumptions on which the plan is based to

insure the timely commitment of the counterattack force.

c. The counterattacking force commander

employs his force in accordance with corps-approved plans, modified as required by the situation or the order implementing the counterattack plan.

Section VII. RETROGRADE OPERATIONS

4-37. General

During retrograde operations, forces move to the rear or away from the enemy for the purpose of preserving integrity for future operations, repositioning forces on more favorable terrain, or reducing a vulnerability. A corps' retrograde operation usually is a combination of the withdrawal, delaying action, and retirement.

4-38. Corps Planning

a. Corps planning for a retrograde operation begins with the preparation of the plan for the next mission. After developing the corps plans for the mission to be undertaken after the retrograde, it plans its retrograde operations.

b. The corps retrograde plan includes—

- (1) Location, composition, and mission of the corps covering force.
- (2) Organization of the corps for combat.
- (3) Employment of nuclear and chemical weapons when appropriate.
- (4) Control measures, including traffic control.
- (5) Delay times.
- (6) Combat service support for the operation.

4-39. Corps Covering Force

a. Ideally, the corps commander employs a covering force during a retrograde operation. The covering force delays the enemy for a specified period of time, disorganizes the attacking enemy forces as much as possible, and deceives the enemy as to the location and future operations of the corps.

b. A retrograde operation is designed to preserve the integrity of the command; therefore, when the enemy has forced a retrograde movement, the requirement for a strong covering force may be indicated. The capabilities of the armored and mechanized divisions make them the most suitable units for the nucleus of the covering force. The division may be reinforced by attachment of additional combat units, field artillery, surface-to-surface missiles, air defense artillery, and engineers.

c. The corps commander prescribes the mission, composition, and initial location of the

covering force. The covering force accomplishes its mission by delay on successive positions, by delay on alternate positions, or by a combination of the two.

4-40. Organization of the Corps for Combat

a. The corps commander determines the composition of the corps covering force and organizes the corps for the retrograde operation. The main body of the corps disengages, moves through the covering force, and continues its rearward movement. After disengaging, the corps commander relies on the covering force and the organic and supporting reconnaissance and surveillance means to maintain contact with the enemy forces during the retrograde.

b. The retrograde is conducted through decentralized execution. To facilitate coordination of the retrograde movement, the majority of the combat and combat support units of the corps are normally attached to the divisions. A small reserve is retained by the corps.

c. During the initial phase of a retrograde operation, units in the forward defense area, except for delaying or security elements, disengage from the enemy force. When operating on an extended front, the corps commander frequently attaches corps artillery units to the divisions. As the retrograding units pass through the covering force, designated corps artillery units may be attached to the covering force. Control of these units is returned to corps artillery as soon as practicable.

d. Centralized operational control of most nondivisional ADA will normally rest with the area/regional air defense commanders. However, the corps commander should retain operational control of sufficient ADA units for attachment to the covering force.

e. Corps engineer units have two basic missions in retrograde operations:

- (1) Assist the movement of the corps.
- (2) Impede the advance of the enemy by construction of obstacles and planned destruction of installations, supplies, and structures.

Engineer units prepare demolitions, emplace minefields, and conduct other engineer tasks in accordance with plans and priorities.

4-41. Control of the Retrograde Movement

a. The corps retrograde plan includes those control measures necessary to insure a coordinated operation. The corps establishes lateral boundaries between the divisions, phases the operation, and indicates the amount of delay desired between positions. Phase lines may be used for control as appropriate.

b. Retrograde operations require increased traffic control measures that provide priorities of movement and preclude congestion on all retrograde routes. Detailed traffic control plans are made at all echelons, and their execution is decentralized to the lowest levels.

c. As the forward units move through the

corps covering force, traffic control becomes the corps' responsibility in moving to the new defensive position. The corps establishes holding areas at critical points on retrograde routes where congestion is likely to occur so that convoys may be routed into these areas and dispersed. When congestion on the retrograde route is reduced, convoys resume their retrograde movement.

4-42. Supporting Operations

The corps plans and conducts electronic warfare, cover and deception, and barrier and denial operations in support of the retrograde.

Section VIII. TACTICAL NUCLEAR OPERATIONS

4-43. Levels of Nuclear Intensity

An understanding of the level, scale, or intensity of nuclear conflict is necessary to provide a framework for a discussion of tactical nuclear operations.

a. *Restricted Nuclear Environment.* The phrase "restricted use of nuclear weapons" denotes a range of operational environments wherein the employment of nuclear weapons is selective in both quantity and yield and the weapon effects do not reach a level that will materially reduce the ability of combat units to maneuver effectively.

(1) In a restricted nuclear environment, maneuver will remain the key to domination and control of the battlefield. The retention of this domination will depend, to a large degree, on the ability of the corps to reduce its vulnerability to nuclear attack, while at the same time increasing the effectiveness of its offensive operations.

(2) The forms of offensive maneuver and the forms of defense will be applicable in the conduct of battle during a restricted nuclear environment. Because maneuver remains the dominant expression of battlefield superiority, conventional corps doctrine with some modifications remains applicable. However, retention of the initiative at any level of nuclear intensity will involve greater risk. Dispersion, a high degree of mobility, and skillfully executed, decentralized operations will be the most effective means of reducing vulnerability, preserving force integrity, and retaining the initiative by the corps.

(3) The preservation of a maneuver-dominant, restricted nuclear environment will depend on effective political restraints on nuclear

weapon employment, honored without escalation by either side.

b. *Unrestricted Nuclear Environment.* The phrase "unrestricted use of nuclear weapons" is used to depict a level of nuclear weapon employment that is sufficiently high to preclude the effectiveness of maneuver by combat units.

(1) In an unrestricted nuclear environment, maneuver is no longer feasible, and the battle area is completely dominated by nuclear fires. The initiative is held by the force that has achieved nuclear fire superiority. Retention of the initiative is predicated on the ability of one force to effectively destroy the nuclear delivery capability of the opposing force. Decisive results will accrue to the force that gains nuclear fire superiority and at the same time preserves sufficient maneuver elements to exploit the fire ascendancy when achieved. Initial use by a combatant will markedly assist in gaining such superiority.

(2) During periods of unrestricted use of nuclear weapons, classical corps-level offensive and defensive operations will not be feasible. Survivability of the corps will depend on prior planning, short response times, and the ability of its major subordinate commands to disperse and operate at the small-unit level on their own initiative for extended periods of time. Subordinate maneuver elements of the corps are not expected to become decisively engaged in combat, but should be employed as target acquisition elements in reconnaissance, surveillance, and security roles.

(3) Those combat and combat support elements of the corps that cannot be effectively employed in the efforts to gain nuclear fire

superiority must be preserved for the subsequent exploitation phase. A significant portion of the corps may fall into this category. These forces must be dispersed and concealed in protected positions. The primary mission of these elements will be the retention of operational integrity and survival.

c. The Transitional Period. The extremes of restricted versus unrestricted use of nuclear weapons occupy opposite ends of the spectrum of tactical nuclear operations. The phrase "transitional period" is used to identify the nuclear environment that would exist between the two extremes during an escalation of the nuclear exchange from a restricted to an unrestricted nuclear environment. The level of employment of nuclear weapons during the transitional period would range from the selective employment in quantity, yield, or type of target to the threshold of the opposite extreme of battlefield saturation. The transitional period may last for only a few hours, or it may span several days or weeks.

(1) The transitional period will include a range of operational environments that permit relative freedom of maneuver to severely curtailed actions. The corps must retain the flexibility and force integrity necessary to conduct limited offensive and defensive operations in support of nuclear fires during the transitional period.

(2) If it becomes clearly evident that the escalation is directed toward achieving nuclear fire superiority, the corps should adopt the posture associated with an unrestricted nuclear environment and retaliate in greater magnitude.

4-44. Operational Considerations

a. Corps Areas of Responsibility and Interest.

(1) Paramount to survival in an active nuclear environment is the dispersion necessary to reduce vulnerability. To insure that adequate space is available for dispersion by the major subordinate commands, the corps area of responsibility is increased. The size of the corps area of responsibility will depend on the mission, the nature and characteristics of the terrain, the size of the corps and the forces available, the enemy situation, the enemy nuclear threat and other situational variables. The area of responsibility will fluctuate with the requirement for greater or lesser dispersion as the level of nuclear intensity fluctuates. Portions of the corps area of responsibility may be controlled by nuclear fires depending on the surveillance and target acquisition capabilities and weapons available.

(2) Since the enemy forces will also disperse, the corps area of interest will increase. The corps area of interest extends beyond the area of influence to include the enemy forces and weapon delivery systems that are capable of influencing the battle.

b. Organization for Combat. Divisions and lower echelons of the corps must be capable of conducting semiindependent operations of limited scope on their own initiative. This requires the decentralization of combat support and combat service support to the maximum extent practicable.

c. Fire and Maneuver. The traditional relationships between the functions of land combat are subject to drastic change as the tactical use of nuclear weapons is introduced. As the level of nuclear intensity increases, nuclear fires become the predominant expression of combat power, while small tactical forces are committed in support of nuclear fires. As this reversal of roles takes place, the corps must disperse, conceal, and take protective measures for all units that are not required for surveillance, reconnaissance, or security roles to preserve operational integrity and enhance survivability.

d. Tempo of Operations. The destructive effects of nuclear weapons increase the tempo of decisive combat. Engagements will be short and violent. Decisive battles may last hours instead of days or weeks. This requires that the corps possess the capability of rapid assembly of selected forces from dispersed locations, responsive nuclear fires from the smallest units capable of delivery, and a high degree of mobility.

e. Corps Reserve. The maneuver reserve must be held well to the rear to reduce the possibility of detection and damage. The reserve must be well dispersed and concealed in multiple locations, with the required mobility for employment. The corps reserve should not be assigned a mission that requires it to remain massed; it must be capable of rapid assembly and dispersal. The dominant aspect of the corps reserve should be nuclear fires, because they are a more effective, efficient, and decisive application of combat power. Nuclear fires should be used to reduce enemy penetrations, to block enemy forces, to control specific terrain, and for other missions that would otherwise increase the vulnerability of a corps maneuver reserve.

f. Redundancy of Command and Control. The corps headquarters will be a priority target during tactical nuclear operations. Command and control must be retained when headquar-

ters elements are destroyed. Therefore, the redundancy of command and control facilities is essential to continuity of command. Redundancy of the corps CP is discussed in paragraph 4-3.

4-45. Offensive Operations

a. General. In principle, existing doctrine remains valid for the conduct of offensive operations in a restricted nuclear environment, but the manner of execution of operations changes. Numerically inferior forces, properly supported by nuclear weapons and an effective target acquisition capability, can achieve the initiative and retain maneuver superiority. In an unrestricted nuclear environment, large-scale offensive operations are not feasible. This environment is characterized by a nuclear-dominant battle area in which the mission is the achievement of nuclear fire superiority.

b. Corps Offensive Operations.

(1) In a tactical nuclear environment corps offensive operations are characterized by maneuver forces operating in dispersed formations to exploit the effects of nuclear strikes and to acquire additional targets for nuclear destruction.

(2) Because of their destructiveness, nuclear weapons permit the adoption of courses of action that may not be feasible during nonnuclear operations and, thus, require the same detailed consideration given to the employment of major subordinate units. The employment of nuclear weapons is one of the commander's major considerations during the formulation of planning guidance.

(3) The assignment/allocation of nuclear weapons to the major subordinate commands follows the same pattern as task assignment in a phased operation; i.e., the commander assigns nuclear weapons to the divisions for one phase of the corps operation and provides an allocation for succeeding phases.

(4) The use of nuclear weapons facilitates the rupture of the enemy's principal defensive position to permit greater latitude in the adoption of the penetration or envelopment by the corps commander.

(5) The overwhelming destruction caused by the extensive employment of tactical nuclear weapons facilitates the accomplishment of operational phases in hours rather than days or weeks. Corps and subordinate commanders must plan for and be prepared to execute an exploitation or pursuit shortly after the initiation of the attack.

(6) As long as the enemy retains even a limited nuclear delivery capability, he remains a significant threat to freedom of action and maneuver.

4-46. Defensive Operations

a. General. Defensive operations will require modification in the disposition of forces as the transition is made from a restricted to an unrestricted nuclear environment. In the restricted environment, conventional defensive posture and tactics will be the norm. As the intensity increases, so will the departure from conventional tactics.

b. Defensive Operations.

(1) As defensive operations make the transition from restricted to unrestricted use of nuclear weapons, they are characterized by an increase in the use of nuclear weapons and a corresponding decrease in the employment of maneuver forces. The depth and width of defensive areas are increased, and the attacking enemy forces are subjected to nuclear destruction as they attempt to penetrate the battle area.

(2) Corps control of operations in a nuclear environment are characterized by decentralization. Subordinate commanders conduct operations on their own initiative, but in conformance with the overall corps defensive plan.

(3) The primary mission of the covering force is to detect approaching enemy forces and to destroy or disorganize them with nuclear fires. The covering forces are employed as target acquisition elements and are not expected to engage in close combat. Within the forward defense area, dispersed units engage attacking enemy forces to force them to mass. Once the enemy has massed, his destruction is sought by nuclear fires. Counterattacks are characterized by an exploitation of nuclear fires.

Section IX. COMBAT SUPPORT OF THE CORPS

4-47. General.

This section discusses the missions and general method of employment of combat support units. Combat support provided by other Services is also discussed where appropriate. Combat sup-

port units assigned or attached to a corps normally remain under the operational control of the corps headquarters. However, depending on the source of mission requirements, span of control capabilities of all command echelons,

and the physical disposition of the combat support elements, they may be further attached to the COSCOM.

4-48. Fire Support

a. General. Fire support means under corps control include the nuclear and nonnuclear fires of assigned and attached cannon, rocket, and missile artillery and attack helicopter weapon systems. Tactical air support is provided to corps by the Air Force. When appropriate, naval gunfire support may also be provided.

b. Field Artillery. Long-range, surface-to-surface ballistic missiles may be retained under operational command of the theater commander. All other nondivisional field artillery will normally be assigned to the corps.

(1) Corps artillery provides depth to the battlefield; augments the fires of the divisions; provides counterbattery fires; and performs corpswide target acquisition functions. Corps normally controls the operations of nondivisional field artillery. The corps commander accomplishes control and coordination by assigning tactical missions to subordinate units, attaching artillery to subordinate units, providing survey and communication to the field artillery with the corps, and prescribing available supply rates.

(2) Types of missions assigned to corps field artillery units are general support (GS), reinforcing (Reinf), and general support-reinforcing (GSR). These units may be attached to the divisions, separate brigade, or armored cavalry regiment. At the recommendation of the corps artillery commander, the corps commander assigns missions to the division artillery of reserve elements. Field artillery support is also provided to nondivisional elements when these forces are committed. In offensive operations, the main attack of the corps is given priority of field artillery support. The use of nuclear weapons reduces the requirement for massed conventional fires. Corps usually attaches field artillery to an exploiting force. FM 6-20 contains detailed discussions of the employment of field artillery units.

c. Air Defense Artillery. Corps will normally be structured with organic low-to-medium-altitude air defense artillery (ADA) units. High-to-medium-altitude air defense units may also be assigned or attached to the corps when this coverage is not provided by higher echelons. Although the regional air defense commander has full authority and responsibility for air defense of the region in which the corps is employed, the corps commander will normally

retain operational control of his organic corps air defense artillery. However, employment of the corps ADA is subject to theater air defense rules and procedures. These rules and procedures may include conditions of readiness; air defense warnings; rules of engagement; weapon control status; hostile criteria; rules for initial release of nuclear weapons and for warhead selection; coordinating and reporting instructions; and the direct coordination and information exchange links with the area/regional air defense control facilities. A discussion of the theater air defense system is contained in paragraph 3-7. FM 44-1 and JCS Pub 8 contain detailed discussions of air defense operations.

d. Fire Support Coordination Line. The fire support coordination line (FSCL) is an imaginary line arranged, if possible, to follow well-defined geographical features. It is established by the corps commander to coordinate supporting fires delivered by forces not under corps control. The location and the effective time of the FSCL are coordinated with supporting tactical air, naval gunfire, and adjacent units and with higher headquarters. The FSCL is routinely established beyond the farthest point to which the corps intends to employ forces on the ground. This permits supporting fires, not under the control of the corps commander, to attack targets beyond the FSCL without danger to or coordination with the corps. Supporting forces outside the corps must coordinate with the corps before engaging targets short of the FSCL. However, field artillery and naval gunfire under corps control may deliver fire between the FSCL and the no-fire line (NFL), established by the divisions, without coordination. FM 6-20 contains additional details on the establishment of the FSCL.

e. Tactical Air Support.

(1) The theater commander apportions available tactical air assets to each of the tactical air functions of counterair, air interdiction, and tactical air support. Based on the recommendations from the theater army and corps commanders, the theater commander will allocate the Army's portion of tactical air support. Normally the bulk of the tactical airlift devoted to combat service support will be allocated to the theater army.

(2) Tactical air support provided to the corps includes close air support, tactical air reconnaissance, and tactical airlift. Planning for tactical air support is closely integrated with corps operational planning and is projected as far into the future as possible.

(3) The organization of the Air Force tacti-

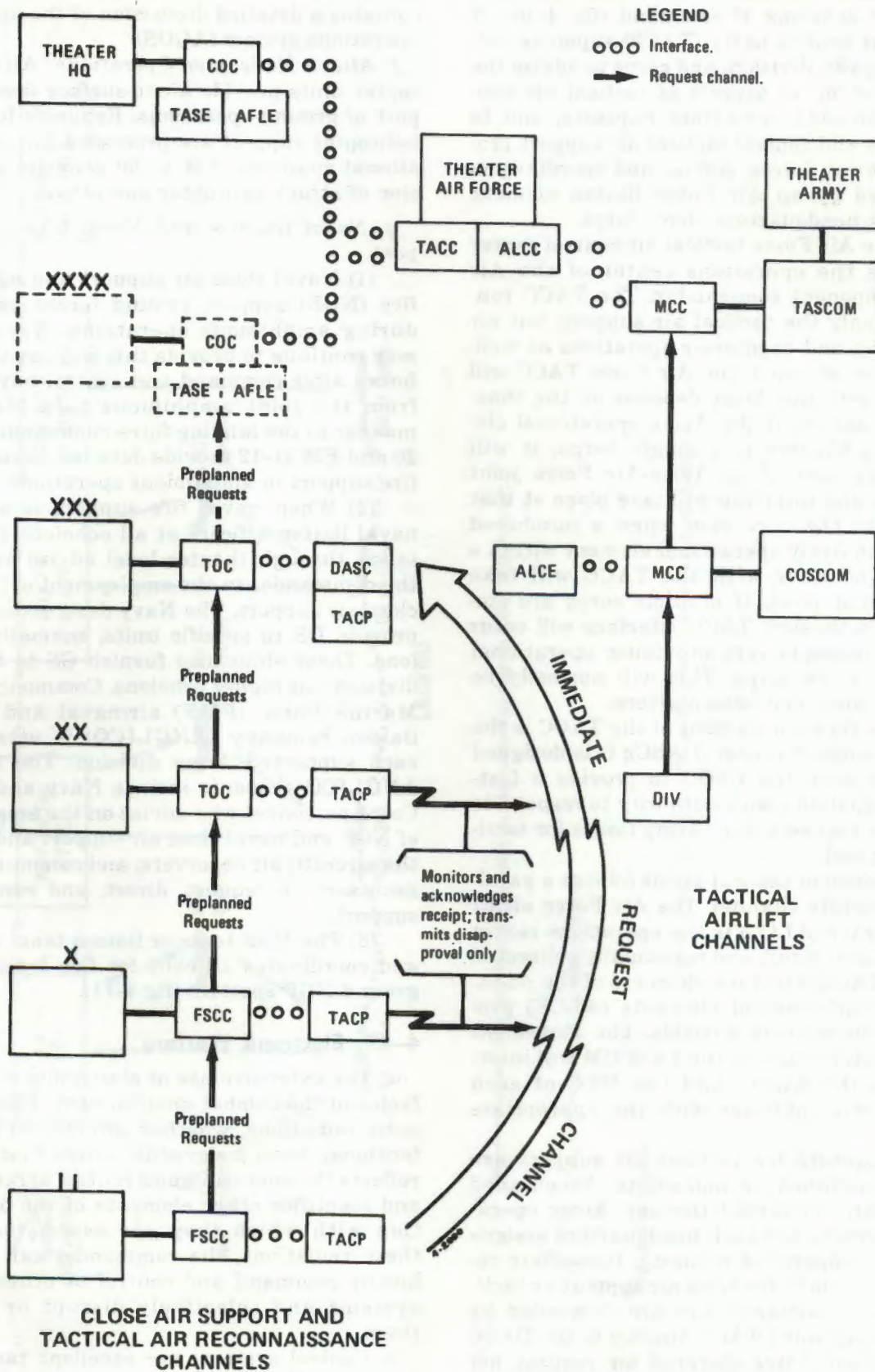

Figure 4-10. Tactical air support request channels.

cal air control system (TACS) closely parallels the Army echelons of command (fig 4-10). A tactical air control party (TACP) supports battalion, brigade, division, and corps to advise the commander on all aspects of tactical air support, to forward immediate requests, and to coordinate and control tactical air support provided to Army forces. Advice and coordination is provided by an Air Force liaison element (AFLE) at headquarters above corps.

(4) The Air Force tactical air control center (TACC) is the operations center of the Air Force component commander. The TACC controls not only the tactical air support, but air interdiction and counterair operations as well. The echelon at which the Air Force TACC will interface with the Army depends on the theater organization. If the Army operational element in a theater is a single corps, it will function as part of an Army-Air Force joint task force and interface will take place at that echelon. In the rare case when a numbered army is the Army operational element within a theater, interface with the TACC will take place at that level. If multiple corps are employed in a theater, TACC interface will occur with the headquarters providing operational direction to the corps. This will normally be unified or combined headquarters.

(5) The forward element of the TACC is the direct air support center (DASC); it is designed to operate with the CTOC to provide a fast-reaction capability with authority to respond to immediate requests from Army forces for tactical air support.

(6) Control of tactical airlift follows a parallel but separate channel. The Air Force airlift control center (ALCC) is the operations center for all tactical airlift and is normally collocated with the TACC. Forward elements of the ALCC are the airlift control elements (ALCE) provided at the various airfields. The movement control center (MCC) of the TASCOSCOM will interface with the ALCC, and the MCC of each COSCOM will interface with the appropriate ALCE.

(7) Requests for tactical air support are either preplanned or immediate. Preplanned requests are forwarded through Army operational channels, and each headquarters assigns priorities to approved requests. Immediate requests are usually for close air support or tactical air reconnaissance and are forwarded by the initiating unit's TACP directly to the DASC using the Air Force-operated air request net (fig 4-10). If any intermediate commander disapproves the request or substitutes another support means, the TACP at that headquarters notifies the DASC at corps and the originating

TACP, who notifies the requester. FM 100-26 contains a detailed discussion of the air-ground operations system (AGOS).

f. Attack Helicopter Operations. Attack helicopter units provide air-to-surface fires in support of ground operations. Requests for attack helicopter support are processed through operational channels. FM 1-100 provides a discussion of attack helicopter operations.

g. Naval Gunfire and Naval Close Air Support.

(1) Naval close air support and naval gunfire (NGF) support ground forces principally during amphibious operations. Naval forces may continue to provide this support to ground forces after command and control have passed from the joint amphibious task force commander to the landing force commander. FM 6-20 and FM 31-12 provide detailed discussions of fire support in amphibious operations.

(2) When naval fire support is available, naval liaison officers at all echelons from battalion through theater level advise and assist the commander in the employment of NGF and close air support. The Navy designates ships to provide DS to specific units, normally battalions. These ships also furnish GS to brigades, divisions, or higher echelons. Commonly a Fleet Marine Force (FMF) air/naval and gunfire liaison company (ANGLICO) is attached to each supported Army division. The attached ANGLICO elements include Navy and Marine Corps personnel who advise on the employment of NGF and naval close air support and provide the aircraft, air observers, and communications necessary to request, direct, and control this support.

(3) The NGF team or liaison team monitors and coordinates all calls for fire from air and ground NGF spotters (fig 4-11).

4-49. Electronic Warfare

a. The extensive use of electronics is a major factor of the combat environment. Electromagnetic radiations, whether intentional or unintentional, have a signature effect that directly reflects the command and control arrangement and identifies other elements of the organization with which they are associated. From these radiations, the commander can identify hostile command and control or other control systems and selectively disrupt or deceive them.

b. Control systems are excellent targets for jamming. For example, disruption of aircraft navigation systems, air-to-ground missile guidance systems, and VT fuze systems, serve to reduce the combat effectiveness of the enemy.

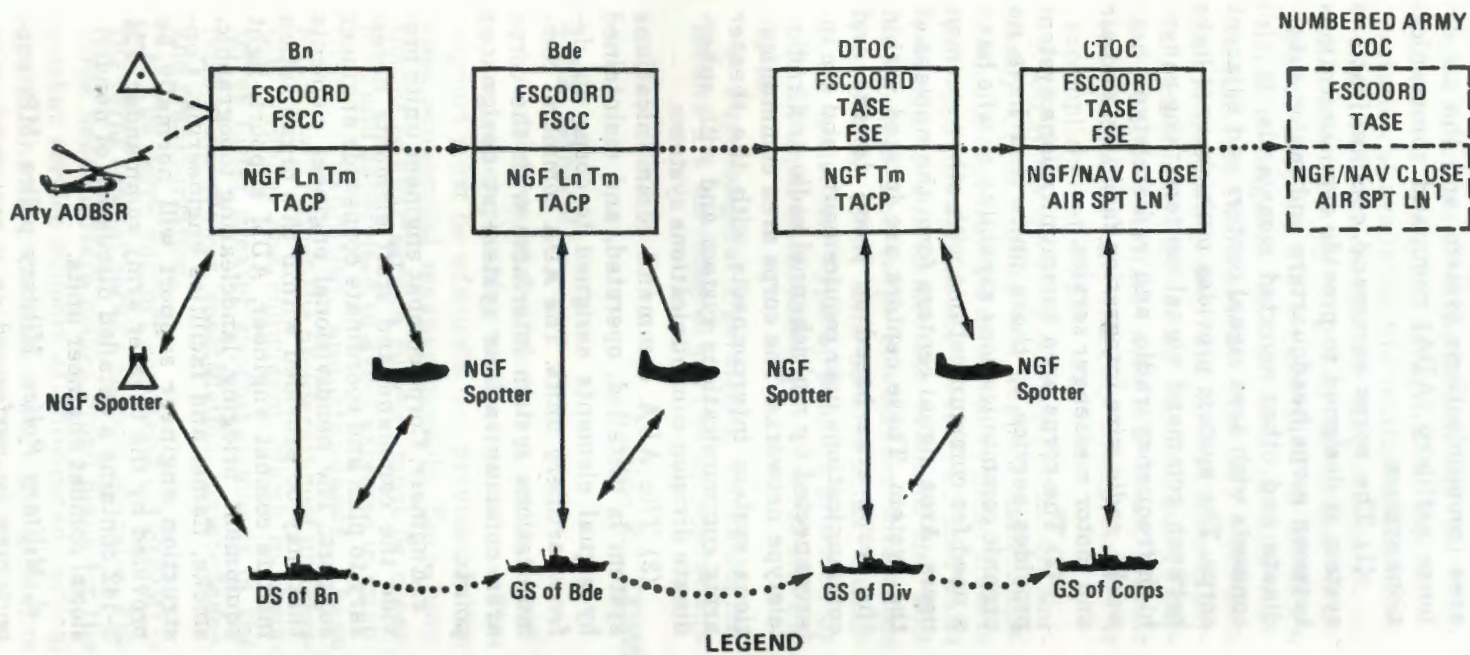

Figure 4-11. Naval gunfire and naval close air support channels.

c. An electronic warfare (EW) system that enables the commander to reduce the effectiveness of hostile electronic activities and, at the same time, insure effective use of his own electronics represents a powerful weapon in support of both offensive and defensive operations. Electronic operations conducted within and in support of the corps include intelligence, target acquisition, jamming, cover and deception, security, and command and control. All contribute to a command's available combat power.

d. The enemy's capability to utilize electronic countermeasures and the necessary action on the part of the corps to protect its own electronic systems must be considered in all corps operations. Plans must be formulated to employ electronic counter-countermeasures if required. When necessary, corps assigns specific EW tasks to subordinate elements. AR 10-122, AR 105-2, AR 105-87, FM 32-10, and FM 32-20 provide detailed discussions of EW.

4-50. Cover and Deception Operations

a. Properly conceived and employed, cover and deception (C&D) operations deceive the enemy as to the true disposition, capabilities, and intentions of friendly forces. A corps may employ cover and deception measures assigned by a higher headquarters, or a corps may develop a cover and deception plan to support its own concept of operations. However, C&D operations initiated by the corps must be approved by the next higher commander.

b. Cover and deception plans must be developed concurrently with the OPLAN they are to support. The deception measures must be initiated in sufficient time to allow the enemy to acquire the false or misleading information, analyze the activity or inactivity, and react to the intended deception in the desired manner. These operations require strict security measures; therefore, minimum essential distribution of the C&D annex should be made.

c. FM 31-40 provides a detailed discussion of C&D operations.

4-51. Other Corps Combat Support

a. *Army Aviation.* Army aviation elements provide the commander with the means to better employ the functions of land combat. The high cost and complexity of this equipment require centralized control and support. Corps provides Army aviation support to subordinate elements by placing units under their operational control, assigning a DS or GS mission to the aviation unit, or attaching the unit for the duration of an operation or for a specific period.

b. *Communications-Electronics.* The corps

communications systems are installed and operated by the organic corps signal element. Communication support at the corps level is provided by three separate systems: the corps command communications system, the corps area communications system, and the air defense artillery (ADA) command communications system.

(1) The corps command communications system is designed to provide communications between corps headquarters and major subordinate and other selected commands. It also connects with area signal centers and adjacent corps. The system provides multichannel links between command signal centers, long-range, high-frequency radio and radioteletype networks, radio wire integration facilities, and air and motor messenger service.

(2) The corps area communications system provides service to those units that have no organic communications capability or who have a need for communications with other common users. Area signal centers form the nucleus of the system. These centers are located within the corps area based on troop density and communications user requirements, and are interconnected by multichannel radio and radioteletype networks. The corps area communications system interconnects with the theater army communications system and with subordinate division communications systems.

(3) The ADA command communications system is installed, operated, and maintained by signal elements assigned to corps air defense artillery units. The ADA command communications system interfaces with the corps area communications system at designated points.

c. *Engineer.* Corps combat engineer units provide the command and staff elements necessary to plan and coordinate corpswide engineer support. The nondivisional engineer elements that may be provided within this organization include combat engineer, ADM support, light equipment, bridging, landclearing topographic, smoke, flame, and facilities engineering. Construction engineer support will normally be provided by the theater army commander. FM 5-142 contains a detailed discussion of nondivisional combat engineer units.

d. *Military Police.* Military police (MP) support may be performed on a command, area, functional, or mission basis. Based on the support to be rendered, a determination is made as to whether the MP unit is attached to or placed in direct support or general support of the supported unit. Types of units that may be found in the corps include guard, escort guard,

physical security, criminal investigative, and general purpose military police units. FM 19-4 contains detailed information regarding MP operations.

e. Military Intelligence. The military intelligence functions at corps include the collection, evaluation, analysis, integration, and interpretation of available information and sources. Specialized sources include target acquisition, ASA, and infantry ranger units. Military intelligence support will be provided to divisions, separate brigades, and armored cavalry regiments. Corpwide support includes collection, technical intelligence, counterintelligence, aerial surveillance, and aerial reconnaissance support units. Interface with Air Force for air reconnaissance and imagery interpretation is accomplished at corps.

f. US Army Security Agency (USASA). Normally USASA units will support each corps. Although centralized direction to these units is provided throughout the theater, USASA units respond to the immediate needs of the unit supported. The corps commander integrates the USASA effort with other military intelligence activities. Type of support provided by USASA units is discussed in AR 10-122 and FM 32-10.

g. Psychological Operations. Psychological factors are an integral part of all operations.

PSYOP include words and actions specifically planned to reduce the combat effectiveness of enemy armed forces and to influence hostile, neutral, and friendly groups to support US operations. The corps commander is responsible for the integration of PSYOP into overall military planning. He must evaluate his plans and operations in view of their psychological impact in consonance with the guidance provided from higher headquarters. The corps is primarily concerned with tactical PSYOP designed to produce short-term results. However, some tactical objectives may have to be altered to achieve longer range PSYOP goals. The corps commander allocates PSYOP companies or teams to subordinate commands as required. FM 33-1 and FM 33-5 provide details of PSYOP.

h. Air Force Weather Support. USAF Air Weather Service (AWS) weather teams and a corps weather center provide weather support for tactical operations. Weather information received by the corps weather center from USAF weather sources is analyzed and tailored to meet requirements of the corps. The corps and division weather teams provide direct weather support for tactical operations. AR 115-10, AR 115-12, and FM 31-3 contain detailed discussions of USAF weather support to corps operations.

Section X. COMBAT SERVICE SUPPORT

4-52. General

a. Combat service support is a major consideration when planning tactical operations. This support must be adequate, yet provided in the most economical manner possible. Each function of combat service support must be examined and supervised to avoid excesses in quantities, capabilities, and standards. These actions will reduce the proliferation of unnecessary supplies and equipment, which in themselves foster greater support demands in the form of manpower, construction, maintenance, and transportation.

b. The corps support command (COSCOM) is the corps combat service support operator. The corps headquarters makes broad plans for the combat service support of anticipated tactical operations in consonance with the guidance received from theater army. The COSCOM develops detailed plans, policies, and directives for combat service support in conformance with corps policies, directives, and guidance.

c. In support of corps plans and orders, COSCOM headquarters conducts its own estimates and analyses and develops its supporting plans.

It determines overall combat service support requirements for the corps; manages the corps reserve stocks; coordinates movements with elements of the TASCOM; develops and manages the maintenance support plan; and balances resources. In addition it coordinates personnel records, management, and pay activities of COSCOM and nondivisional support units. COSCOM accomplishes centralized control, evaluation, and management in three functional areas of material management, movement control, and personnel.

4-53. Organization

The COSCOM is structured to support varying combat, combat support, and combat service support elements of the force. The theater army commander may attach combat service support units to the COSCOM from theater army resources, including the TASCOM and other COSCOM's, in order to effectively support the theater commander's operational plans.

4-54. Civil Affairs

a. The corps commander may be delegated

civil affairs (CA) authority. The delegation of such authority is accompanied by CA resources to accomplish the required civil affairs activities. Normally, during combat operations the primary CA activity will be the prevention of civilian interference with tactical and logistic operations.

b. Civil affairs units include command and control elements and functional teams. These elements are organized into units, appropriate in size and capability to perform a specific CA mission. Functional teams are cellular and vary in size and capability. Teams are made up of individuals who are technically qualified to either supervise or advise in each of the civil affairs functional areas; e.g., governmental, economic, public facilities and special functions.

c. Civil affairs activities may be divided into the following categories—

- (1) Prevention of civilian interference with tactical and logistic activities.
- (2) Provision of support for the functions of government for a civilian population.
- (3) Community relations between the civilian population and military forces.
- (4) Military civic action.
- (5) Military participation in populace and resources control.
- (6) Military support of civil defense.

d. One or more CA units may be attached to or placed in support of a division. Additional structured CA units will be provided to support other combat, combat support, and combat service support units of the corps. In the combat zone, CA may be required within tactical boundaries; however, transition to political boundaries should be accomplished as soon as practicable. FM 41-10 provides doctrine for CA operations.

DOCTRINAL RECAPITULATION

- The corps is a flexible tactical and administrative organization, usually consisting of five divisions, more or less, together with supporting arms and services, structured for specific operational requirements, and charged with territorial responsibility for the combat zone.
- Within a theater in peacetime, the corps will normally be under the command of the theater army commander.
- In time of war, the next echelon above the corps in the operational chain of command will be the unified command or another headquarters the unified command commander might designate; e.g., subordinate unified command, joint task force, or, exceptionally, a numbered army. The theater army commander will exercise command less operational control over the corps.
- The corps commander establishes command relationships within the corps. Combat and combat support units will normally be assigned or attached to the corps headquarters; combat service support will be assigned or attached to the corps support command (COSCOM). A support unit with both combat support and combat service support functions will normally be placed under the headquarters from which it receives the preponderance of its mission requirements.
- The COSCOM is a flexible organization structured to support corps forces. The theater army commander will attach units to a COSCOM from theater army resources to effectively support the theater commander's operational plans.
- Missions assigned to the corps will normally be major tactical actions of the campaign plan that are relatively broad in nature. Exceptionally, they may be explicit and leave little or no latitude in the details of their accomplishment.
- The corps may divide a major tactical action into phases to facilitate planning and execution.
- In the offense, missions assigned to divisions by the corps will usually call for the securing of terrain objectives that facilitate future operations or the destruction of enemy forces or both.
- In the conduct of defensive operations, the corps normally will not specify the form of defense to be conducted by divisions.

- When the corps conducts a mobile defense, at least one FDA element will be given a delay mission.
- In the defense, the counterattack is the decisive offensive action in which the corps reserve is committed at the crucial time and place. Counterattack plans are prepared as an integral part of defensive planning.
- In both offensive and defensive operations, the corps reserve will usually be employed under corps control. It may include nuclear weapons and combat support forces.
- The corps normally employs a follow and support force, usually a division, in the conduct of an exploitation.
- Corps planning for a retrograde operation is based on plans for the mission to be undertaken following the retrograde.
- During a retrograde operation, elements of the corps may be conducting a combination of withdrawal, delaying action, and retirement.
- Corps artillery provides depth to the battle area; augments the fires of division artillery; provides counterbattery fires; and performs corpswide target acquisition functions.
- The corps commander establishes the fire support coordination line (FSCL) to coordinate those fires not under corps control but which may affect current tactical operations. Supporting agencies outside the corps must coordinate with the corps before engaging targets short of the FSCL.
- The cost, complexity, demanding maintenance requirements, mobility, and versatility of Army aviation units are factors that favor centralized control of those units not organic to subordinate elements of the corps. However, they are placed OPCON, attached, or assigned to the supported commander as the accomplishment of the mission requires.
- The direct air support center (DASC), collocated with the corps tactical operation center (CTOC) provides rapid communication and directive authority to satisfy immediate requests for tactical air support.
- The corps commander is responsible for rear area protection (RAP) operations in his corps area. He will normally assign this mission to his COSCOM commander.
- A corps conducting independent operations will normally be part of a joint task force.
- Structuring a corps for contingency operations will be based on the mission, enemy, terrain, and forces available consistent with the principles of simplicity, austerity, flexibility, and realism to achieve the greatest possible combat effectiveness.
- Austerity of Army forces is achieved by minimizing construction, establishing low in-theater stockage levels, establishing a short hospital evacuation policy, restricting general support (GS) supply and maintenance support, providing reduced personnel services, and eliminating nonessential personnel and equipment. To achieve this concept, the Army relies on superior tactical air support, strategic and tactical mobility, and selected combat support and combat service support from the other Service components.

APPENDIX A REFERENCES

1. Army Regulations (AR)

10-1	Functions of the Department of Defense and Its Major Components.
(C)10-122	United States Army Security Agency (U).
(C)105-2	Electronic Counter-Countermeasures (U).
(C)105-87	Electronic Warfare (U).
115-10	Meteorological Support for the United States Army.
115-12	United States Army Requirements for Weather Service Support.
310-25	Dictionary of United States Army Terms.
310-50	Authorized Abbreviations and Brevity Codes.
(C)530-1	Operations Security (U).

2. Department of the Army Pamphlets (DA Pam)

310-series	Military Publications.
310-35	Index to International Standardization Agreements.

3. Joint Chiefs of Staff Publications (JCS Pub)

1	Dictionary of United States Military Terms for Joint Usage.
(O)2	Unified Action Armed Forces (UNAAF).
(C)3	Joint Logistics and Personnel Policy and Guidance (U).
(O)8	Doctrine for Air Defense From Oversea Land Areas.
(O)12	Tactical Command and Control Procedures for Joint Operations.

4. Field Manuals (FM)

1-100	Army Aviation Utilization.
3-1	Chemical, Biological, Radiological (CBR) Support.
5-1	Engineer Troop Organizations and Operations.
5-142	Nondivisional Engineer Combat Units.
6-20	Field Artillery Tactics and Operations.
11-23	Theater Army Communications Command.
11-92	Corps Signal Communications.
17-95	The Armored Cavalry Regiment.
19-4	Military Police Support, Theater of Operations.
19-50	Military Police in Stability Operations.
24-1	Tactical Communications Doctrine.
30-5	Combat Intelligence.
31-3	Weather Support for Field Army Tactical Operations.
31-10	Denial Operations and Barriers.
31-12	Army Forces in Amphibious Operations (The Army Landing Force).
31-16	Counter guerrilla Operations.
31-21	Special Forces Operations—US Army Doctrine.
(S)31-21A	Special Forces Operations—US Army Doctrine (U).
31-23	Stability Operations, US Army Doctrine.
(C)31-40	Tactical Cover and Deception (U).
31-73	Advisor Handbook for Stability Operations.
31-85	Rear Area Protection (RAP) Operations.
(S)32-10	USASA in Support of Tactical Operations (U).
(C)32-20	Electronic Warfare (U).
33-1	Psychological Operations—US Army Doctrine.
33-5	Psychological Operations—Techniques and Procedures.
41-10	Civil Affairs Operation.
44-1	US Army Air Defense Artillery Employment.

54-7	The Theater Army Support Command.
61-100	The Division.
100-5	Operations of Army Forces in the Field.
100-10	Combat Service Support.
100-20	Field Service Regulations—Internal Defense and Development (IDAD).
100-26	The Air-Ground Operations System.
100-30 (Test)	Tactical Nuclear Operations.
101-5	Staff Officers' Field Manual: Staff Organization and Procedure.
101-10-1	Staff Officers' Field Manual: Organizational Technical, and Logistical Data—Unclassified Data.
101-10-2	Staff Officers' Field Manual: Organizational, Technical, and Logistical Data—Extracts of Nondivisional Tables of Organization and Equipment.

101-10-2	Staff Officers' Field Manual: Organizational, Technical, and Logistical Data—Extracts of Nondivisional Tables of Organization and Equipment.	101-10-2
101-10-1	Staff Officers' Field Manual: Organizational Technical, and Logistical Data—Unclassified Data.	101-10-1
101-5	Staff Officers' Field Manual: Staff Organization and Procedure.	101-5
100-30 (Test)	Tactical Nuclear Operations.	100-30
100-26	The Air-Ground Operations System.	100-26
100-20	Field Service Regulations—Internal Defense and Development (IDAD).	100-20
100-10	Combat Service Support.	100-10
100-5	Operations of Army Forces in the Field.	100-5
61-100	The Division.	61-100
54-7	The Theater Army Support Command.	54-7

44-1	US Army Air Defense Artillery Employment.	44-1
43-5	Gen Alliance Operation.	43-5
43-1	Psychological Operations—US Army Doctrine.	43-1
43-20	Electronic Warfare (U).	43-20
43-10	USASA in Support of Tactical Operations (U).	43-10
41-85	Heat Area Protection (HAP) Operations.	41-85
41-78	Advisor Handbook for Stability Operations.	41-78
(C) 41-40	Tactical Cover and Deception (U).	(C) 41-40
41-31	Stability Operations, US Army Doctrine.	41-31
(S) 41-21A	Special Forces Operations—US Army Doctrine (U).	(S) 41-21A
41-16	Special Forces Operations—US Army Doctrine.	41-16
41-10	Army Forces in Amphibious Operations (The Army Landing Force).	41-10
41-70	Special Operations and Barriers.	41-70
41-3	Weather Support for Field Army Tactical Operations.	41-3
40-5	Combat Intelligence.	40-5
34-1	Tactical Communications Doctrine.	34-1
19-50	Military Police in Stability Operations.	19-50
19-4	Military Police Support, Theater of Operations.	19-4
17-45	The Armored Cavalry Regiment.	17-45
11-20	Corps Signal Communications.	11-20
11-27	Theater Army Communications Command.	11-27
6-39	Field Artillery Tactics and Operations.	6-39
4-143	Nondivisional Engineer Combat Units.	4-143
2-1	Engineer Troop Organizations and Operations.	2-1
2-1	Chemical, Biological, Radiological (CBR) Support.	2-1
1-100	Army Aviation Utilization.	1-100

4	Field Manuals (FM)	4
(O) 12	Tactical Command and Control Procedures for Joint Operations.	(O) 12
1/28	Doctrine for Air Defense From Overseas Land Areas.	1/28
(C) 10	Joint Logistics and Personnel Policy and Guidance (U).	(C) 10
40/2	Unified Action Armed Forces (UNAAF).	40/2
7	Dictionary of United States Military Terms for Joint Chiefs.	7
3. Joint Chiefs of Staff Publications (JCS Pub)		3. Joint Chiefs of Staff Publications (JCS Pub)
310-28	Index to International Standardization Agreements.	310-28
310-28	Military Publications.	310-28
3. Department of the Army Pamphlet (DA Pam)		3. Department of the Army Pamphlet (DA Pam)
(C) 30-1	Operations Security (U).	(C) 30-1
110-28	Authorized Abbreviations and Hierarchy Codes.	110-28
410-25	Dictionary of United States Army Terms.	410-25
410-12	United States Army Requirements for Weather Service Support.	410-12
115-10	Meteorological Support for the United States Army.	115-10
410130-87	Electronic Warfare (U).	410130-87

INDEX

	Paragraph	Page
Advance (movement) to contact—corps	4-23	4-13
Air defense—army	3-7	3-3
Air defense artillery—corps	4-48c	4-26
Air Force weather support—corps	4-51h	4-31
Air and naval gunfire liaison company (ANGLICO)	4-48g	4-26
Airlift—tactical (<i>See</i> tactical air support)		
Allocation of combat power	2-13d, 2-14d, 4-34	2-9, 2-10, 4-21
Area of operations (<i>See</i> theater of operations)		
Army aviation—corps	4-51a	4-30
Army role	1-3	1-2
Army Security Agency—corps	4-51f	4-31
Attack helicopter operations—corps	4-48	4-26
Barriers	2-16d	2-11
Biological operations—US policy	1-2d	1-2
Chain of command	2-3	2-1
Chemical operations—US policy	1-2d	1-2
Chief of Staff, US Army	1-3d	1-3
Civil affairs	4-18d, 4-54	4-9, 4-31
Civilian control	1-2a	1-1
Close air support (<i>See</i> tactical air support)		
Combat actions	4-17d	4-8
Combat service support	3-8, 4-13, 4-18, 4-52, 4-53	3-7, 4-5, 4-8, 4-31
Combat support—corps:		
Air Force weather support	4-51h	4-31
Army aviation	4-51a	4-30
Army Security Agency	4-51f	4-31
Communications-electronics	4-51b	4-30
Cover and deception operations	4-50	4-30
Electronic warfare	4-49	4-28
Engineer	4-51e	4-31
Fire support	4-48, 4-48a	4-26
General	4-47	4-25
Military intelligence	4-51e	4-31
Military police	4-51d	4-30
Psychological operations	4-51g	4-31
Combat zone	2-5a	2-4
Combined operations (theater)	2-4	2-3
Commander:		
Numbered army	3-11	3-9
Theater army	3-1, 3-2	3-1
Unified command (theater)	2-2	2-1
Communications	2-17d, 3-7b, 4-17c	2-12, 3-3, 4-8
Communications-electronics	4-51b	4-30
Communications zone	2-5a	2-4
Control measures	4-21	4-10
Counterattack, conduct of—corps	4-36	4-21
Counterattack planning—corps	4-35	4-21
Corps:		
Combat service support Considerations	4-13, 4-18	4-5, 4-8
Combat support	4-47—4-53	4-25—4-31
Command relationships	4-4, 4-11, 4-16	4-3, 4-5, 4-6
Command and staff actions	4-6	4-4
Corps contingency force Operations	4-2a, 4-14, 4-15	4-1, 4-6
Defensive operations	4-29—4-36	4-17—4-21
Definition	4-1	4-1
Forward deployed	4-2a	4-1
Headquarters	4-3	4-1

	Paragraph	Page
Corps—Continued		
Heavy	4-2b	4-1
Light	4-2b	4-1
Offensive operations	4-19—4-28	4-9—4-17
Operational considerations	4-12, 4-17, 4-44	4-5, 4-8, 4-24
Operations in an established theater	4-9, 4-10	4-5
Organization	4-2	4-1
Organization for combat	4-40, 4-44b	4-22, 4-24
Phasing	4-7, 4-38	4-4, 4-22
Planning	4-5	4-3
Retrograde operations	4-37, 4-42	4-22, 4-23
Scope of operation plan or order	4-8	4-4
Tactical nuclear operations	4-43—4-46	4-24, 4-25
Corps support command (COSCOM)	4-52, 4-53	4-31
Cover and deception operations	2-16b, 4-50	2-10, 4-30
Covering force—corps	4-39	4-22
Defensive echelons—corps:		
Forward defense echelon	4-30b	4-17
Reserve echelon	4-30c	4-18
Security echelon	4-30a	4-17
Defensive operations—corps:		
Allocation of combat power	4-34	4-21
Counterattack, conduct of	4-36	4-21
Counterattack planning	4-35	4-21
Defensive echelons	4-30	4-17
Defensive operation estimate	4-32b	4-19
Defensive planning	4-32	4-19
Forms of defense	4-31	4-18
Missions to units in the forward defense area	4-33	4-20
Tactical nuclear operations	4-46	4-25
Defensive operations—theater	2-14	2-9
Denial operations	2-16c	2-11
Electronic warfare	2-16a, 4-49	2-10, 4-28
Engineer	4-51c	4-30
Envelopment—corps	4-22c	4-10
Estimate, defensive operations—corps	4-32b	4-19
Exploitation—corps	4-26	4-16
Field artillery—corps	4-48b	4-26
Fire support—corps	4-48, 4-48a	4-26
Fire support coordination line	4-21, 4-48d	4-10, 4-26
Force structuring	1-2b, 4-10, 4-15	1-1, 4-5, 4-6
Forms of defense—corps:		
Mobile defense	4-31a	4-18
Position defense	4-31b	4-18
Forward defense echelon—corps	4-30b	4-17
Frontal attack—corps	4-22d	4-12
Intelligence	2-8, 3-7a, 4-12c	2-6, 3-3, 4-5
Internal defense and development	3-7f	3-7
International standardization agreements	1-4b, 2-4b	1-3, 2-3
Joint task force	2-12, 4-4	2-8, 4-3
Level of conflict	4-12a, 4-43	4-5, 4-23
Logistics (See also combat service support)	4-18b	4-9
Military intelligence	4-51e	4-31
Military police	4-51d	4-30
Mobile defense—corps	4-31a	4-18
Naval gunfire and naval close air support	4-48g	4-28
Nuclear operations	1-2d, 4-43—46	1-2, 4-23—4
Nuclear weapons:		
Allocation and assignment	2-17a	2-11
Communications	2-17d	2-12
Special ammunition load and stockage	2-17b	2-11

Numbered army:		
Command relationships	3-11	3-9
Functions	3-13	3-9
General	3-10	3-9
Organization	3-12	3-9
Offensive forms of maneuver—corps:		
Envelopment	4-22c	4-10
Frontal attack	4-22d	4-12
Penetration	4-22b	4-10
Offensive operations—corps:		
Advance (movement) to contact	4-23	4-13
Coordination and control	4-21	4-10
Deliberate (coordinated) attack	4-25	4-16
Exploitation	4-26	4-16
Missions	4-20	4-10
Offensive forms of maneuver	4-22	4-10
Pursuit	4-27	4-16
Reconnaissance in force	4-24	4-16
Reserve	4-28	4-17
Tactical nuclear operations	4-45	4-25
Offensive operations—theater	2-13	2-8
Operational command	2-2d	2-1
Operational considerations—corps	4-12, 4-17, 4-44	4-5, 4-8, 4-24
Operational considerations—theater:		
Barriers	2-16d	2-11
Defensive operations	2-14	2-9
Denial operations	2-16c	2-11
Electronic warfare operations	2-16a	2-10
General	2-12	2-8
Operations in a nuclear environment	2-17	2-11
Offensive operations	2-13	2-8
Retrograde operations	2-15	2-10
Operational control	2-2d	2-1
Operational environments	1-2c	1-1
Operational planning	2-9—2-11, 4-5	2-7, 4-3
Penetration—corps	4-22b	4-10
Personnel and administrative services—corps	4-18c	4-9
Phasing—corps	4-7	4-4
Planning:		
Corps	4-5—4-8	4-3, 4-4
Theater	2-7—2-11	2-6, 2-7
Position defense—corps	4-31b	4-18
Psychological operations	3-7d, 4-51g	3-5, 4-31
Pursuit—corps	4-27	4-16
Realistic force structuring	1-2b	1-1
Rear area protection (RAP)	3-9, 4-12d, 4-17e	3-8, 4-5, 4-8
Reconnaissance in force—corps	4-24	4-16
Reconnaissance—air (See tactical air support)		
Reserve—corps	4-28, 4-44e	4-17, 4-24
Reserve echelon—corps	4-30c	4-18
Restricted nuclear environment	4-43a	4-23
Retrograde operations—corps:		
Control of	4-41	4-23
Covering force	4-30	4-17
General	4-37	4-22
Organization for combat	4-40	4-22
Planning	4-38	4-22
Supporting operations	4-42	4-23
Retrograde operations—theater	2-15	2-10
Secretary of the Army	1-3c	1-3
Security echelon—corps	4-30a	4-17
Special ammunition load and stockage	2-17b	2-11
Special forces (See unconventional warfare operations)		
Tactical air support	4-48e	4-26

	Paragraph	Page
Tactical nuclear operations:		
Corps reserve	4-44e	4-24
Defensive operations	4-46	4-25
Levels of nuclear intensity	4-43	4-23
Offensive operations	4-45	4-25
Operational considerations	4-44	4-24
Redundancy of command and control	4-44f	4-24
Restricted nuclear environment	4-43a	4-23
Tempo of operations	4-44d	4-24
Transitional period	4-43c	4-24
Unrestricted nuclear environment	4-43b	4-23
Theater army:		
Air defense	3-7c	3-4
Combat service support	3-8	3-7
Combat support	3-7	3-3
Command relationships	3-2	3-1
Communications	3-7b	3-3
Functions	3-6	3-3
Headquarters organization	3-3	3-1
Intelligence	3-7a	3-3
Internal defense and development	3-7f	3-7
Mission	3-1	3-1
Psychological operations	3-7d	3-5
Rear area protection (RAP)	3-9	3-8
Staff	3-4	3-2
Territorial responsibility	3-5	3-2
Unconventional warfare operations	3-7e	3-5
Theater army support command (TASCOM)	3-8c, d	3-7
Theater of operations:		
Chain of command	2-3	2-1
Combined operations (theater)	2-4	2-3
Commander	2-2	2-1
Command structure	2-6	2-6
Definition	2-1	2-1
Territorial organization	2-5	2-4
Theater operational considerations:		
Barriers	2-16d	2-11
Cover and deception	2-16b	2-10
Defensive operations	2-14	2-9
Denial operations	2-16c	2-11
Electronic warfare operations	2-16a	2-10
General	2-12	2-8
Offensive operations	2-13	2-8
Operations in a nuclear environment	2-16e	2-11
Retrograde operations	2-15	2-10
Theater planning:		
Basis	2-7	2-6
Considerations	2-10	2-7
Intelligence	2-8	2-6
Scope	2-9	2-7
Subordinate commanders	2-11	2-7
Unconventional warfare operations	3-7e	3-5
Unified command	2-2	2-1
Unrestricted nuclear environment	4-43b	4-23
Weather support, Air Force	4-51h	4-31

By Order of the Secretary of the Army:

CREIGHTON W. ABRAMS
General, United States Army
Chief of Staff

Official:

VERNE L. BOWERS
Major General, United States Army
The Adjutant General

Distribution:

Active Army, ARNG, USAR: To be distributed in accordance with DA Form 12-11B requirements for Larger Units: Theater Army-Corps (Qty rqr block no. 407).

FM 100-15 (TEST) LARGER UNIT OPERATIONS-1974